



**AGENDA
DRAINAGE DISTRICT
BOARD OF DIRECTORS
May 5, 2015
9:00 A.M.**

NOTICE is hereby given in accordance with Chapter 551, Texas Government Code, that a SPECIAL MEETING of the Drainage District #1 Board of Directors will be held at the Edinburg Council Chambers, 415 W. University Drive, Edinburg, Hidalgo County, Texas. Discussion and possible action relating to the following business will be transacted:

1. **Roll Call**
2. **Prayer**
3. **Open Forum**
4. **Approval of Consent Agenda**
5. **AI -49521** A. Discussion and action on the proposed "Amendments to the original/current Letter of Engagement" including, but not limited to, the following items [as more specifically detailed in supporting document titled Amended Letter of Engagement attached herein and [as approved-HCDD#1-BOD-01-22-15]:
 1. AMEND: Expiration date of original agreement [using working days not calendar days];
 2. AMEND/EXTEND: to May 15, 2015 [using working days not calendar days];
 3. AMEND: Original scope of services to include '.....conflict of interest issues...' and contained in proposed "Amended Letter of Engagement";
 4. BOD FINDING: Acceptance and approval of the PL coverage of \$500K

B. Discussion and action on Second Amendment to Letter of Engagement for additional time from May 15, 2015 to August 15, 2015 in order to complete the additional scope of work approved by HCDD#1-BOD related to '.....conflicts of interest issues' on the Integ Contract.

6. **AI -49535** Request approval to issue manual payment once review and audit procedures are complete on the following items:
 - A. Request for Payment No. 1 in the amount of \$70,965.00 from Foremost Paving Inc. related to Construction Contract No. HCDD1-14-003-02-05-Pct. 4 West Main Drain. PO#624506.
 - B. Request for Payment No. 2 in the amount of \$60,525.00 from Foremost Paving Inc. related to Construction Contract No. HCDD1-14-003-02-05-Pct. 4 West Main Drain. PO#624506.
 - C. Request for Payment No. 3 Final- Retainage Release in the amount of \$24,779.50 from Foremost Paving Inc. related to Construction Contract No. HCDD1-14-027-10-08-HCDD#1-North Main Weir#1. PO#625973.

7. Discussion on Hidalgo County Drainage District No. 1 Drainage projects, maintenance and operations

8. **Closed Session:**
 Board of Directors may go into Closed Session pursuant to Chapter 551, Texas Government Code, Sections 551.071 & 551.072 to discuss the following:
 - A. **Real Estate Acquisition**
 - B. **Pending and/or Potential Litigation**

9. **Open Session:**
 - A. **Real Estate Acquisition**
 - B. **Pending and/or Potential Litigation**

10. **Closed Session:**
 Board of Directors may reconvene into Closed Session for the discussion regarding the agenda items listed

11. **Open Session:**
 Board of Directors may reconvene into Open Session for the discussion regarding the agenda items listed

12.

Adjourn

AI -49521

5.

DRAINAGE DISTRICT

Meeting Date: 05/05/2015

Submitted For: Marty Salazar

Submitted By: Vangie Garcia,
PURCHASING DEPT.

Department: PURCHASING DEPT.

Information

CAPTION

A. Discussion and action on the proposed "Amendments to the original/current Letter of Engagement" including, but not limited to, the following items [as more specifically detailed in supporting document titled Amended Letter of Engagement attached herein and [as approved-HCDD#1-BOD-01-22-15]:

- 1. AMEND: Expiration date of original agreement [using working days not calendar days];
- 2. AMEND/EXTEND: to May 15, 2015 [using working days not calendar days];
- 3. AMEND: Original scope of services to include '.....conflict of interest issues...' and contained in proposed "Amended Letter of Engagement";
- 4. BOD FINDING: Acceptance and approval of the PL coverage of \$500K

B. Discussion and action on Second Amendment to Letter of Engagement for additional time from May 15, 2015 to August 15, 2015 in order to complete the additional scope of work approved by HCDD#1-BOD related to '.....conflicts of interest issues' on the Integ Contract.

BACKGROUND

Fiscal Impact

FISCAL YEAR: 2015

ACCOUNT #: 110-433-006-43330

FUNDS AVAILABLE? Y/N:

MATCHING FUNDS? Y/N:

BUDGETARY IMPACT:

Attachments

- Original Letter of Engagement
- correspondence
- Amended letter

Form Review

Inbox

Budget & Management

Final Approval

Form Started By: Vangie Garcia

Final Approval Date: 05/01/2015

Reviewed By

Veronica Ortiz

Monica Badillo

Date

04/30/2015 11:37 AM

05/01/2015 03:23 PM

Started On: 04/30/2015 09:46 AM

C.Approval to set salaries for District Employees and Travel Allowance for Board Members.

On motion by COMMISSIONER PCT. 4, JOSEPH PALACIOS, seconded by COMMISSIONER PCT. 3, JOE M. FLORES, the Board made a UNANIMOUS vote of approval.

Vote: 5 - 0 - Unanimously

D.Adoption of the 2014 Tax Rate.

On motion by COMMISSIONER PCT. 3, JOE M. FLORES, seconded by COMMISSIONER PCT. 1, A.C. CUELLAR, JR., the Board made a UNANIMOUS vote of approval.

Vote: 5 - 0 - Unanimously

The Board proceeded to Item 7.

6. **AI-46732** Pursuant to correspondence received from The Lee Law Firm (on 09-25-14), awarded firm (but as yet no letter of engagement executed) for: Professional Legal Services for the Review and Report of the Agreement between Hidalgo County Drainage District #1 and Integ Corporation" requesting the HCDD#1 Board of Directors consider, discuss, accept and approve, deny or modify, the following language regarding term of service: no less than 30 days no more than 100 days in order to include in final document so as to execute and commence legal employment timeline.

Commissioner Joseph Palacios joined the meeting.

Commissioner A.C. Cuellar, Jr., stated that he thought they had previously approved the terms of service to be 30 days. Mrs. Marty Salazar informed the Board that the Lee Law Firm sent notice requesting a consideration of revision of the terms due to their litigation calendar and other commitments.

Commissioner Joe Flores joined the meeting.

Mrs. Salazar stated that the Board can deny it and go out for bids again. She stated that the process was lengthy and there is no other firm to work with. The Board was in agreement to offer the term of no less than 30 days with no more than 90 days. Mrs. Salazar stated that once they sign the letter of engagement, the time line will commence.

On motion by COMMISSIONER PCT. 3, JOE M. FLORES, seconded by COMMISSIONER PCT. 4, JOSEPH PALACIOS, the Board made a UNANIMOUS vote of approval to modify the term of service to no less than 30 days with no more than 90 days.

Vote: 5 - 0 - Unanimously

The Board proceeded to Item 5.

APPROVED

AI-46732

6.

DRAINAGE DISTRICT

Meeting Date: 09/30/2014

Submitted For: Valde Guerra, HCCC-EO

Submitted By: Marty Salazar, PURCHASING DEPT.

Department: PURCHASING DEPT.

Information

CAPTION

Pursuant to correspondence received from The Lee Law Firm (on 09-25-14), awarded firm (but as yet no letter of engagement executed) for: Professional Legal Services for the Review and Report of the Agreement between Hidalgo County Drainage District #1 and Integ Corporation" requesting the HCDD#1 Board of Directors consider, discuss, accept and approve, deny or modify, the following language regarding term of service: no less than 30 days no more than 100 days in order to include in final document so as to execute and commence legal employment timeline.

BACKGROUND

Attachments

- 1
- 2

Form Review

Inbox	Reviewed By	Date
Purchasing Department	Marty Salazar	09/26/2014 12:39 PM
Budget & Management	Debbie Tamez	09/26/2014 01:29 PM
Auditor's Office	Monica Badillo	09/26/2014 05:04 PM
Form Started By: Marty Salazar		Started On: 09/26/2014 09:53 AM
Final Approval Date: 09/26/2014		

LETTER OF ENGAGEMENT FOR LEGAL SERVICES

RFQ No: HCDD1-14-140-06-04-VYG

Professional Legal Service in connection with the review and report for the agreement between Hidalgo County Drainage District No. 1 and Integ Corporation

This Agreement is made by and between Michael S. Lee/The Lee Firm, A Professional Corporation (“Attorney”), and Hidalgo County Drainage District No. 1 (“Client”) to review and report for the agreement between Hidalgo County Drainage District No. 1 and Integ Corporation.

1. **Scope of Services.** The Attorney will provide legal services as requested by Client and accepted by Attorney on a case-by-case and matter-by-matter assignment. Attorney shall provide those legal services reasonably required to represent Client, and shall keep Client informed of the progress of the case or matter. In order to enable Attorney to render effective legal services, Client shall provide all facts and keep Attorney informed of all developments relating to the matter. Attorney must rely on the accuracy and completeness of the facts and information provided by Client. In addition, Attorney will provide legal services in reviewing all documents related to the contractual issues between Hidalgo County Drainage District No. 1 and Integ Corporation; review appropriate Texas case law, whether statutory and/or common law; conferences and meetings with Hidalgo County Drainage District No. 1 representatives; interviews and conferences with any subcontractors and/or other contractors involved in the project developments that are the subject of the issues between Hidalgo County Drainage District No. 1 and Integ Corporation; interview witnesses; provide appropriate legal opinions relating to same.
2. **Fees.** Hourly fees for legal services are based on the amount of time each lawyer or paralegal spends working on the Client’s behalf multiplied by their respective hourly rate. Hourly rates vary among professionals depending on experience, level of expertise and market conditions. Hourly rates are reviewed annually and will be adjusted only with the Client’s written consent. The fee structure accepted for this matter is stated in the attached Exhibit “A”. Lead counsel and all attorneys and legal staff working on the assigned matter shall be identified in the attached fee structure.
3. **Expenses.** By engaging services from Attorney, Client authorizes third-party contracting necessary for representation on Client’s behalf and such costs shall be reimbursed for actual costs as incurred as per schedule of costs attached as Exhibit “A”, although this list may not be all inclusive. The Attorney will seek approval from Client for any individual expenses that are expected to exceed the sum of \$500.00. Attorney shall also obtain Client’s consent before retaining an outside investigator, consultant or expert witness.
4. **Billing.** The Client shall be billed monthly for fees, costs and expenses incurred (detailed in the attached Exhibit “A”) and will reimburse firm for actual expenses incurred in connection with litigation. The Client shall also pay for the time the Attorney spends traveling, (when necessary). Hourly and/or timed billing shall be submitted in increments of one-tenth (1/10th) of an hour. No block billing shall be accepted. Each billing entry shall separately itemize the activity or task performed and the amount of corresponding time. All billing invoices are subject to review by the County Auditor as provided for under the Texas Local Government Code. Payment of billing invoices requires approval by the Hidalgo County Drainage District No. 1.
5. **Termination.** This agreement will terminate once the case or matter assigned is completely resolved/dismissed, or in the event the Client chooses to terminate the agreement in advance of

completion, resolution or final dismissal of the matter, then upon written notice of termination. The term of service is for no less than 30 days no more than 90 days with the commencement of professional legal employment date of October 13, 2014.

6. Client approval is necessary for settlement. Attorney is authorized to engage in settlement negotiations if and when appropriate in their professional judgment. No settlement of any nature shall be made for any of the claims or causes of action of Client without the complete approval of Client. Upon Client approval, Attorney shall have full authority to sign papers or documents regarding settlement. This provision is subject to the terms and conditions of the policy of insurance that indemnifies Client for the claims in the above matter.
7. Entire Agreement. This Agreement contains the entire understanding and agreement between the parties with respect to its subject matter (*i.e.*, the review and report for the agreement between Hidalgo County Drainage District No. 1 and Integ Corporation) and supersedes any prior or contemporaneous written or oral agreements, representations or warranties between the parties herein.
8. Amendment. This Agreement may be amended only by written amendment with the approval of the Hidalgo County Drainage District No. 1 and their duly authorized agent or representative.
9. Governing Law. This Agreement shall be construed in accordance with the laws of the State of Texas which law shall govern any actions arising hereunder. Any dispute arising hereunder shall be brought before a court of competent jurisdiction in Hidalgo County, Texas.

AGREED:

LAW FIRM:

The Lee Firm, A Professional Corporation

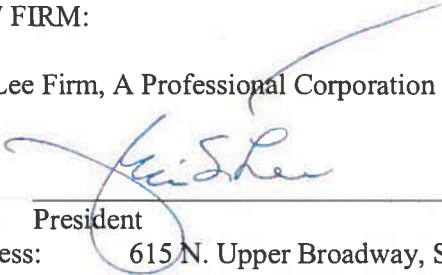
By: 
Title: President
Address: 615 N. Upper Broadway, Suite 708
Corpus Christi, Texas 78401
Telephone: 361.882.4444
Fax: 361.882.7844
E-mail: theleefirmpc@theleefirm.com
Date: October 2, 2014

HIDALGO COUNTY DRAINAGE
DISTRICT NO. 1

By: 
Title: _____
Address: 2812 S. Business Hwy 281
Edinburg, Texas 78539

Approved by Commissioners' Court
on 9/30/2014 RW

Exhibit "A"
**SCHEDULE OF COSTS IN CONNECTION WITH LEGAL REPRESENTATION
INVOLVING HIDALGO COUNTY DRAINAGE DISTRICT NO. 1
AND INTGEG CORPORATION**

Attorney Fees: **Hourly Rate:**
Attorneys: See Attached
Legal Assistant: See Attached

Legal Fees/Court Costs:

Filing Fees	Actual costs
Service of Process & Subpoenas	Actual costs
Mediation Fees	Actual costs
Legal Research Expenses	Actual costs (Lexis Nexis)
Depositions (Court Reporter & Video as appropriate)	Actual costs
Internet Search Fees	Actual costs
Witness Fees	Actual required by law
Expert Witness Fees	Actual costs
Hearing Transcript Fees (as appropriate)	Actual costs
Investigator Fees (as appropriate)	Actual costs

Travel Expenses:

Mileage Rate (IRS guidelines recommended) – Prevailing IRS Rate
Air Travel (most economical travel recommended) – Most economical taking into consideration travel time.
Hotel (most economical recommended – not to exceed \$100.00 per day)
Meals (to be reimbursed only if traveling out of town – not to exceed \$39.00 per day)

Office Expense:

Faxes	\$1.25 per page
Copies	\$.30 per page
Binding	As charged by Texas Star Documents
Telephone (Long Distance only)	As charged by Foremost

Postage and Express Mail:

U.S. Mail	Actual costs
Express Mail	Actual costs
Other:	
Overnight Delivery	Actual costs

Itemized receipts must be provided for each expense.

Send billing to: Hidalgo County Drainage District No. 1
 ATTN: Evangelina Garcia
 Hidalgo County Purchasing Department
 2812 S. Business Hwy. 281
 Edinburg, Texas 78539
 E-mail: Evangelina.garcia@co.hidalgo.tx.us

CHARGES FOR ATTORNEY FEES AND LEGAL ASSISTANT

Michael S. Lee Senior Attorney	\$250.00 per hour
Peter C. Ruggero Senior Attorney Of Counsel	\$250.00 per hour
Contract Senior Attorney/Of Counsel	\$250.00 per hour
Contract Junior Attorney/Of Counsel	\$200.00 per hour
Senior Paralegal	\$125.00 per hour
Junior Paralegal	\$100.00 per hour
Investigator	\$100.00 per hour
Administrative Tasks	\$75.00 per hour

Zimbra

evangelina.garcia@co.hidalgo.tx.us

Re: HCDD1-14-140-06-004-VYG

From : Evangelina Garcia <evangelina.garcia@co.hidalgo.tx.us>**Thu, Apr 30, 2015 02:56 PM****Subject :** Re: HCDD1-14-140-06-004-VYG**To :** The Lee Firm PC <TheLeeFirmPC@theleefirm.com>**Cc :** cynthia castro <cynthia.castro@co.hidalgo.tx.us>, paguilar@ramongarcia-law.com, Darlene H. Betancourt <darlene.betancourt@co.hidalgo.tx.us>, Martha Salazar <martha.salazar@co.hidalgo.tx.us>, lora briones <lora.briones@hcdd1.org>

Honorable Michael Lee;

Can you please include the additional time you are requesting for the additional scope of services detailed in the amended document as everything else appears to be included as discussed.

Please forward as soon as possible as we are aiming to have this agenda item on for Tuesday, May 5, 2015 and will need to attach to the agenda as supporting documentation.

Appreciate your assistance on this.

Thank you;

Vangie Y. Garcia, Contract Manager
Hidalgo County Purchasing Department
2812 S. Business Hwy. 281
Edinburg, Texas 78539
Email: evangelina.garcia@co.hidalgo.tx.us
Phone: 956-292-7000-Ext. 4856

From: "The Lee Firm PC" <TheLeeFirmPC@theleefirm.com>**To:** "Martha Salazar" <martha.salazar@co.hidalgo.tx.us>**Cc:** "Evangelina Garcia" <evangelina.garcia@co.hidalgo.tx.us>, "cynthia castro" <cynthia.castro@co.hidalgo.tx.us>, paguilar@ramongarcia-law.com, "Darlene H. Betancourt" <darlene.betancourt@co.hidalgo.tx.us>**Sent:** Wednesday, April 29, 2015 6:01:31 PM**Subject:** HCDD1-14-140-06-004-VYG

Re: HCDD1-14-140-06-004-VYG

Ms. Salazar:

Attached please find correspondence dated April 29, 2015 along with the stated enclosure.

Michael S. Lee
The Lee Firm, A Professional Corporation
615 N. Upper Broadway, Suite 708
Corpus Christi, Texas 78401
Telephone: 361.882.4444

Zimbra

evangelina.garcia@co.hidalgo.tx.us

HCDD1-14-140-06-004-VYG

From : The Lee Firm PC <TheLeeFirmPC@theleefirm.com>

Wed, Apr 29, 2015 06:01 PM

Subject : HCDD1-14-140-06-004-VYG 2 attachments**To :** 'Martha Salazar' <martha.salazar@co.hidalgo.tx.us>**Cc :** 'Evangelina Garcia' <evangelina.garcia@co.hidalgo.tx.us>, cynthia castro <cynthia.castro@co.hidalgo.tx.us>, paguilar@ramongarcia-law.com, 'Darlene H. Betancourt' <darlene.betancourt@co.hidalgo.tx.us>

Re: HCDD1-14-140-06-004-VYG

Ms. Salazar:

Attached please find correspondence dated April 29, 2015 along with the stated enclosure.

Michael S. Lee
The Lee Firm, A Professional Corporation
615 N. Upper Broadway, Suite 708
Corpus Christi, Texas 78401
Telephone: 361.882.4444
Facsimile: 361.882.7844
E-mail Reply to: theleefirmpc@theleefirm.com

 **To Martha Salazar 04-29-15 sending Amended Letter of Engagement.pdf**
42 KB **AMENDED LETTER OF ENGAGEMENT FOR LEGAL SERVICES 01-30-15.pdf**
241 KB

615 N UPPER BROADWAY, SUITE 708
CORPUS CHRISTI, TEXAS 78401-0732
TELEPHONE: 361/882-4444

126 W MAIN, SUITE B
P O BOX 599 (MAIL)
KENEDY, TEXAS 78119
TELEPHONE: 830/583-0899

THE LEE FIRM
A PROFESSIONAL CORPORATION
ATTORNEYS AT LAW

TOLL FREE: 800/580-4444
FAX: 361/882-7844
EMAIL: THELEEFIRMP@THELEEFIRM.COM

MICHAEL S LEE
BOARD CERTIFIED
PERSONAL INJURY TRIAL LAW
TEXAS BOARD OF LEGAL SPECIALIZATION

REPLY TO CORPUS CHRISTI ADDRESS

April 29, 2015

Via E-mail -- martha.salazar@co.hidalgo.tx.us

Martha Salazar
Hidalgo County Purchasing Department
2812 S. Business Hwy. 281
Edinburg, Texas 78539

Re: HCDD1-14-140-06-004-VYG
Professional Legal Services - Review and Report-Agreement between Hidalgo County
Drainage District No.1 and Integ Corp.

Dear Ms. Salazar:

Attached please find an "Amended Letter of Engagement for Legal Services". As you are aware, there have been discussions about expanding the scope to include further investigation concerning conflicts of interest that may have existed with Hidalgo County Drainage District No. 1 and Integ Corporation. Recently, I sent a proposed "template" concerning the possible distinction of the scope of work. I have not received confirmation that it was acceptable. Notwithstanding, if it is acceptable and should be included in an "Amended Letter of Engagement for Legal Services" we will do so. However, it will require additional time to complete. I will have my report concerning my original work assignment to the Hidalgo County Drainage District No. 1 Board on or before May 19, 2015 as set out in the "Amended Letter of Engagement for Legal Services".

Let me hear from you.

Yours very truly,

Michael S. Lee

MSL/cm

SATELLITE OFFICES - BY APPOINTMENT ONLY
AUSTIN • GOLIAD • KENEDY

Martha Salazar
April 29, 2015
Page 2

cc: Evangelina Garcia
Via E-mail – evangelina.garcia@co.hidalgo.tx.us

Darlene H. Bentancourt
Via E-mail – darlene.bentancourt@co.hidalgo.tx.us

Ramon Garcia
Via E-mail – paguilar@ramongarcia-law.com

Cynthia Castro
Via E-mail – Cynthia.castro@co.hidalgo.tx.us

Zimbra

evangelina.garcia@co.hidalgo.tx.us

Re: Hidalgo County Drainage District - Contract Amendment

From : Martha Salazar <martha.salazar@co.hidalgo.tx.us>

Mon, Apr 27, 2015 01:17 PM

Subject : Re: Hidalgo County Drainage District - Contract Amendment

2 attachments

To : The Lee Firm PC <TheLeeFirmPC@theleefirm.com>**Cc :** cynthia castro <cynthia.castro@co.hidalgo.tx.us>, Evangelina Garcia <evangelina.garcia@co.hidalgo.tx.us>, Raul Sesin <raul.sesin@hcdd1.org>, Valde Guerra <valde.guerra@co.hidalgo.tx.us>

Mr. Lee:

Will your amendment also include all other amendments previously approved by HCDD#1-BOD and discussed with you via teleconference on or about 2-27-15 [with summary of same sent to you via e-mail by Ms. Evangelina Garcia, Contract Mgr. from HC Purchasing Dept.]. We have attached the inclusive e-mail describing what was still needed from you with respect to various amendments to the initial letter of engagement.

Please respond as soon as possible.

Yours truly,
Marty Salazar

From: "The Lee Firm PC" <TheLeeFirmPC@theleefirm.com>
To: "cynthia castro" <cynthia.castro@co.hidalgo.tx.us>**Cc:** "Martha Salazar" <martha.salazar@co.hidalgo.tx.us>**Sent:** Friday, April 24, 2015 4:28:33 PM**Subject:** Hidalgo County Drainage District - Contract Amendment

Re: Hidalgo County Drainage District – Contract Amendment

Ms. Castro:

Attached please find a Memorandum dated April 24, 2015.

Michael S. Lee
The Lee Firm, A Professional Corporation
615 N. Upper Broadway, Suite 708
Corpus Christi, Texas 78401
Telephone: 361.882.4444
Facsimile: 361.882.7844
E-mail Reply to: theleefirmpc@theleefirm.com

From : Jaime Longoria <jaime.longoria@co.hidalgo.tx.us>

Tue, Apr 07, 2015 09:02 AM

Subject : Re: Draft Amendment Templates**To :** Martha Salazar <martha.salazar@co.hidalgo.tx.us>**Cc :** Ramon Garcia <ramon.garcia@co.hidalgo.tx.us>, Valde Guerra <valde.guerra@co.hidalgo.tx.us>, Darlene H. Betancourt <darlene.betancourt@co.hidalgo.tx.us>, Evangelina Garcia <evangelina.garcia@co.hidalgo.tx.us>, Monica Badillo <monica.badillo@co.hidalgo.tx.us>

615 N UPPER BROADWAY, SUITE 708
CORPUS CHRISTI, TEXAS 78401-0732
TELEPHONE: 361/882-4444

126 W MAIN, SUITE B
P O BOX 599 (MAIL)
KENEDY, TEXAS 78119
TELEPHONE: 830/583-0899

THE LEE FIRM
A PROFESSIONAL CORPORATION
ATTORNEYS AT LAW

TOLL FREE: 800/580-4444
FAX: 361/882-7844
EMAIL: THELEEFIRMPC@THELEEFIRM.COM

MICHAEL S LEE
BOARD CERTIFIED
PERSONAL INJURY TRIAL LAW
TEXAS BOARD OF LEGAL SPECIALIZATION

REPLY TO CORPUS CHRISTI ADDRESS

MEMORANDUM

TO: Cynthia Castro *Via E-mail – Cynthia.castro@co.hidalgo.tx.us*

FROM: The Lee Firm, A Professional Corporation - Michael S. Lee

DATE: April 24, 2015

RE: Hidalgo County Drainage District

SUBJECT: Contract Amendment

Ms. Castro:

As a follow up to our most recent telephone conference, this Memorandum will confirm the following:

In 2014 the Hidalgo County Drainage District (District) retained The Lee Firm, A Professional Corporation (The Lee Firm) to investigate and evaluate the contract that was entered into between Integ Corporation (Integ) and the District as it related to compensation paid to Integ, related to the Hidalgo County Master Drainage System Phase II and the federal Border Infrastructure Improvement Project. Currently, The Lee Firm has been working within that scope guidelines. However, the District wishes to amend the scope of the contract between itself and The Lee Firm. The District requests The Lee Firm to expand the scope of its professional evaluation and to analyze any potential conflicts of interests related to Integ, Godfrey Garza and the District as well as contractors who had contracted with the District. As a result, the District authorizes The Lee Firm to file a Petition to Investigate under Texas Rule of Civil Procedure 202 in order to request a Presiding Judge that the District be allowed to take depositions under oath and gather facts and evidence through such discovery in order to determine whether or not there are in fact potential conflicts. The District requests The Lee Firm to investigate any potential conflicts of interest involving any contract or subcontracts related to both the District, more specifically Hidalgo County Master Drainage System Phase II, as well as the federal Border Infrastructure Improvement Project. If the Presiding Judge will allow such investigate discovery to proceed forward, The Lee Firm will do such and will provide the District with any analysis of any conflicts of interest revealed by its discovery and investigation. Also,

SATELLITE OFFICES - BY APPOINTMENT ONLY
AUSTIN • GOLIAD • KENEDY

Memorandum to Cynthia Castro
April 24, 2015
Page 2

The Lee Firm will submit to the District an appropriate amended contract if this scope is in fact accurate.

Ms. Castro, please review the above and if it does meet the District's intent for the amendment of our scope of participation, please so confirm and we will go forward with an amended contract.

I look forward to hearing from you.

Yours very truly,



Michael S. Lee

MSL/cm

cc: Martha Salazar
Via E-mail -- martha.salazar@co.hidalgo.tx.us

Zimbra

evangelina.garcia@co.hidalgo.tx.us

Fwd: HCDD1-14-140-06-004-VYG-IMMEDIATIE REVIEW AND RESPONSE REQUIRED AND URGENTLY REQUESTED

From : Martha Salazar <martha.salazar@co.hidalgo.tx.us>

Wed, Feb 04, 2015 02:20 PM

Subject : Fwd: HCDD1-14-140-06-004-VYG-IMMEDIATIE REVIEW AND RESPONSE REQUIRED AND URGENTLY REQUESTED

2 attachments

To : Ramon Garcia <ramon.garcia@co.hidalgo.tx.us>, ac cuellar <ac.cuellar@co.hidalgo.tx.us>, Honorable Jose M. Flores <joe.flores@co.hidalgo.tx.us>, eduardo cantu <eduardo.cantu@co.hidalgo.tx.us>, joseph palacios <joseph.palacios@co.hidalgo.tx.us>, Valde Guerra <valde.guerra@co.hidalgo.tx.us>, Monica Badillo <monica.badillo@co.hidalgo.tx.us>

Cc : Jaime Longoria <jaime.longoria@co.hidalgo.tx.us>, raul lozano <raul.lozano@co.hidalgo.tx.us>, armando garzajr <armando.garzajr@co.hidalgo.tx.us>, mona parras <mona.parras@co.hidalgo.tx.us>, marcos lopez <marcos.lopez@co.hidalgo.tx.us>, gloria beltran <gloria.beltran@co.hidalgo.tx.us>, Estanislado Ramos <stan.ramos@co.hidalgo.tx.us>, rebecca gomez <rebecca.gomez@co.hidalgo.tx.us>, Evangelina Garcia <evangelina.garcia@co.hidalgo.tx.us>, Darlene H. Betancourt <darlene.betancourt@co.hidalgo.tx.us>

Board of Directors-Hidalgo County Drainage District #1:**Gentlemen:**

Attached for your review and comment is the latest correspondence received from Hon. Michael Lee in response to e-mail sent to the firm on 01-22-2015 as a result of action taken by the Board at it's meeting of 01-20-2015. I was very specific to the "draft" amendment document the firm needed to submit incorporating all the issues discussed and approved by the Board. We sent the firm numerous notices via e-mail and phone calls from 01-28-15 until 02-03-15 without any response. We have received a response (attached). In it, Hon. Michael Lee, states he acknowledges receipt of the request the amendment and accepts all items EXCEPT for the one which requests additional services regarding "conflict of interest....".

I am requesting some direction and response from the Board as it concerns the following:

1. Can we ask Mr. Lee to incorporate all he acknowledges and accepts into a draft Amendment to his current agreement so as to present to the Board for action/approval?
2. As we cannot rely on either the DA's Office or Atlas, Hall & Rodriguez for assistance, who is going to provide Mr. Lee with the more "specific/detailed" scope of work/direction in connection with the conflict of interest matter on the Board's agenda of 01-20-15? In addition, it appears that Mr. Lee is also alluding to the possibility of more time necessary to address the conflict of interest issue.

Please advise as to how to proceed? We need to address these issue asap. I am aware that a meeting is set for Monday, February 9, 2015. Do you wish to place an item to settle these issues and perhaps invite Hon. Michael Lee to be present and finalize this situation.

Yours truly,
Marty S.

From: "The Lee Firm PC" <TheLeeFirmPC@theleefirm.com>**To:** "Martha Salazar" <martha.salazar@co.hidalgo.tx.us>

Cc: "Evangelina Garcia" <evangelina.garcia@co.hidalgo.tx.us>, "Darlene H. Betancourt" <darlene.betancourt@co.hidalgo.tx.us>, paguilar@ramongarcia-law.com, "jaime longoria" <jaime.longoria@co.hidalgo.tx.us>

Sent: Tuesday, February 3, 2015 5:24:05 PM**Subject:** HCDD1-14-140-06-004-VYG

Re: HCDD1-14-140-06-004-VYG
Professional Legal Services – Review and Report-Agreement between Hidalgo County Drainage District No. 1 and Integ Corp.

Dear Ms. Salazar:

Attached please find correspondence dated February 3, 2015.

Michael S. Lee
The Lee Firm, A Professional Corporation
615 N. Upper Broadway, Suite 708
Corpus Christi, Texas 78401
Telephone: 361.882.4444
Facsimile: 361.882.7844
E-mail Reply to: theleefirmpc@theleefirm.com

MSL/cm

From : Evangelina Garcia <evangelina.garcia@co.hidalgo.tx.us>

Wed, Jan 28, 2015 04:38 PM

Subject : Fwd: Amend & Extend current Letter of Engagement between HCDD#1 and The Lee Law Firm

 1 attachment

To : theleefirmpc <theleefirmpc@theleefirm.com>

Cc : Martha Salazar <martha.salazar@co.hidalgo.tx.us>, Israel Ramon <israel.ramon@co.hidalgo.tx.us>, Arturo C. Cuellar <ac.cuellar@co.hidalgo.tx.us>, Eduardo Cantu <eduardo.cantu@co.hidalgo.tx.us>, The Honorable Joe M. Flores <joe.flores@co.hidalgo.tx.us>, The Honorable Joseph Palacios <joseph.palacios@co.hidalgo.tx.us>, Valde Guerra <valde.guerra@co.hidalgo.tx.us>, Jaime Longoria <jaime.longoria@co.hidalgo.tx.us>, Raul Lozano <raul.lozano@co.hidalgo.tx.us>, Armando Garza Jr. <armando.garzajr@co.hidalgo.tx.us>, mona parras <mona.parras@co.hidalgo.tx.us>, marcos lopez <marcos.lopez@co.hidalgo.tx.us>, Monica Badillo <monica.badillo@co.hidalgo.tx.us>, Estanislado Ramos <stan.ramos@co.hidalgo.tx.us>, Yolanda Chapa <yolanda.chapa@co.hidalgo.tx.us>

Honorable Michael Lee;

I am following up on the status of the following email sent to you on January 22, 2015 on the matters of the amending and extending the current letter of engagement between HCDD#1 and The Lee Law Firm. It is important that you provide the requested information as soon as possible so as to proceed with an agenda item for action. We are wanting to place an item for the next court date of February 4th so as to take care of this.

Appreciate your assistance on this pending matter.

Thank you;

Vangie Y. Garcia, Contract's Manager
Hidalgo County Purchasing Department
2812 S. Business Hwy. 281
Edinburg, Texas 78539
Email: evangelina.garcia@co.hidalgo.tx.us
Phone: 956-292-7000-Ext. 4856

From: "Martha Salazar" <martha.salazar@co.hidalgo.tx.us>

To: theleefirm@theleefirm.com, "Ramon Garcia" <ramon.garcia@co.hidalgo.tx.us>, "ac cuellar" <ac.cuellar@co.hidalgo.tx.us>, "eduardo cantu" <eduardo.cantu@co.hidalgo.tx.us>, "Honorable Jose M. Flores" <joe.flores@co.hidalgo.tx.us>, "joseph palacios" <joseph.palacios@co.hidalgo.tx.us>, "Valde Guerra" <valde.guerra@co.hidalgo.tx.us>

Cc: "Jaime Longoria" <jaime.longoria@co.hidalgo.tx.us>, "raul lozano" <raul.lozano@co.hidalgo.tx.us>, "armando garzajr" <armando.garzajr@co.hidalgo.tx.us>, "mona parras" <mona.parras@co.hidalgo.tx.us>, "marcos lopez" <marcos.lopez@co.hidalgo.tx.us>, "rebecca gomez" <rebecca.gomez@co.hidalgo.tx.us>, "Evangelina Garcia" <evangelina.garcia@co.hidalgo.tx.us>

Sent: Thursday, January 22, 2015 3:11:51 PM

Subject: Amend & Extend current Letter of Engagement between HCDD#1 and The Lee Law Firm

Hon. Michael Lee:
Attn: Ms. Carolyn Massengale

Pursuant to action taken by the Board of Director for Hidalgo County Drainage District #1 meeting of 01-20-2015, please draft and forward an Amendment to your current letter of engagement to include the following items:

- 1. AMEND:** Expiration date of original agreement (not appearing on document) on "business days" basis with accompanying calculations (see attached calendar which includes the 6 holidays as ordered by BOD) is determined to be February 20, 2015 (please include);
- 2. AMEND/EXTEND:** BOD approval of The Lee Law Firm's request for additional sixty (60) "business days" extension including (2 holidays as ordered by BOD) which results in the expiration date of May 19, 2015 (with date to be included in draft document);
- 3. AMEND:** Original "scope of services" as defined in HCDD#1-BOD meeting agenda of 01-20-15 (AI#48184):
'.....conflict of interest issues that may have occurred in awarding of contracts on HCDD#1 projects between 2007-2014' as it relates to Integ. Inc. and sub-contractors engaged by District awarded contractors;
- 4. BOD-FINDING:** Acceptance and approval of the Lee Law Firm's Professional Liability Insurance with the limits of \$500K.

We ask that you provide the "draft amendment" document as soon as possible so as to get it reviewed and approved as a form acceptable to HCDD#1 and thereafter execute same. If you require any further information or have questions, please do not hesitate to contact me or Ms. Evangelina Garcia at the HC-Purchasing Dept. through our e-mails or call 956-292-7611 or 956-292-7000, Ext. 4856 respectively.

Respectfully,
Martha L. "Marty" Salazar

From : Evangelina Garcia <evangelina.garcia@co.hidalgo.tx.us>

Thu, Jan 22, 2015 02:59 PM

Subject : Fwd: CALENDAR

 1 attachment

To : Martha Salazar <martha.salazar@co.hidalgo.tx.us>

Cc : Darlene H. Betancourt <darlene.betancourt@co.hidalgo.tx.us>

Ms. Marty,

Attached you will find a copy of the calendar for the Lee Law Firm

Vangie Y. Garcia, Contract's Manager
Hidalgo County Purchasing Department
2812 S. Business Hwy. 281
Edinburg, Texas 785339
Email: evangelina.garcia@co.hidalgo.tx.us
Phone: 956-292-7000-Ext. 4856

From: "Evangelina Garcia" <evangelina.garcia@co.hidalgo.tx.us>

To: "Martha Salazar" <martha.salazar@co.hidalgo.tx.us>

Cc: "Darlene H. Betancourt" <darlene.betancourt@co.hidalgo.tx.us>

Sent: Friday, January 16, 2015 2:26:55 PM

Subject: CALENDAR

Marty;

Attached for your review for approval is information of calendar with days/holidays pursuant to business days and/or calendar days with applicable credit and without.

Let me know if this is what we discussed and or if you want any changes.

Thank you;

Vangie Y. Garcia, Contract's Manager
Hidalgo County Purchasing Department
2812 S. Business Hwy. 281
Edinburg, Texas 78539
Email: evangelina.garcia@co.hidalgo.tx.us
Phone: 956-292-7000-Ext. 4856

 **CALENDER INFO.docx**
14 KB [View](#) [Download](#)

 **To Martha Salazar 02-03-15.pdf**
139 KB

615 N UPPER BROADWAY, SUITE 708
CORPUS CHRISTI, TEXAS 78401-0732
TELEPHONE: 361/882-4444

126 W MAIN, SUITE B
P O BOX 599 (MAIL)
KENEDY, TEXAS 78119
TELEPHONE: 830/583-0899

THE LEE FIRM
A PROFESSIONAL CORPORATION
ATTORNEYS AT LAW

TOLL FREE: 800/580-4444
FAX: 361/882-7844
EMAIL: THELEEFIRMP@THELEEFIRM.COM

MICHAEL S LEE
BOARD CERTIFIED
PERSONAL INJURY TRIAL LAW
TEXAS BOARD OF LEGAL SPECIALIZATION

REPLY TO CORPUS CHRISTI ADDRESS

February 3, 2015

Via E-mail – martha.salazar@co.hidalgo.tx.us

Martha Salazar
Hidalgo County Purchasing Department
2812 S. Business Hwy. 281
Edinburg, Texas 78539

Re: HCDD1-14-140-06-004-VYG
Professional Legal Services - Review and Report-Agreement between Hidalgo County
Drainage District No.1 and Integ Corp.

Dear Ms. Salazar:

Receipt of your correspondence of January 22, 2015 containing “proposed amendments” to my current Letter of Engagement with the Hidalgo County Drainage District No. 1 is hereby acknowledged. I have reviewed it and I accept all of the “proposed amendments” except the new proposed amendment in paragraph 3 of your e-mail correspondence relating to paragraph 1 of the Letter of Engagement which states: “AMEND: Original ‘scope of services’ as defined in HCDD#1-BOD meeting agenda of 01-20-15 (AI#48184): ‘.....conflict of interest issues that may have occurred in awarding of contracts on HCDD#1 projects between 2007-2014’ as it relates to Integ, Inc. and sub-contractors engaged by District awarded contractors”. Unfortunately, this is too broad of a description and I cannot determine what is the scope and whether or not it would be acceptable. Furthermore, I need to have specifics in order to confirm the time that has been allotted for this investigation process. Therefore, please be more specific.

I will wait for your response. If you have any questions, please give me a call.

Yours very truly,



Michael S. Lee

MSL/cm

SATELLITE OFFICES - BY APPOINTMENT ONLY
AUSTIN • GOLIAD • KENEDY

615 N UPPER BROADWAY, SUITE 708
CORPUS CHRISTI, TEXAS 78401-0732
TELEPHONE: 361/882-4444

126 W MAIN, SUITE B
P O BOX 599 (MAIL)
KENEDY, TEXAS 78119
TELEPHONE: 830/583-0899

THE LEE FIRM

A PROFESSIONAL CORPORATION
ATTORNEYS AT LAW

TOLL FREE: 800/580-4444
FAX: 361/882-7844
EMAIL: THELEEFIRMPC@THELEEFIRM.COM

MICHAEL S LEE
BOARD CERTIFIED
PERSONAL INJURY TRIAL LAW
TEXAS BOARD OF LEGAL SPECIALIZATION

REPLY TO CORPUS CHRISTI ADDRESS

April 29, 2015

Via E-mail -- martha.salazar@co.hidalgo.tx.us

Martha Salazar
Hidalgo County Purchasing Department
2812 S. Business Hwy. 281
Edinburg, Texas 78539

Re: HCDD1-14-140-06-004-VYG
Professional Legal Services - Review and Report-Agreement between Hidalgo County
Drainage District No.1 and Integ Corp.

Dear Ms. Salazar:

Attached please find an "Amended Letter of Engagement for Legal Services". As you are aware, there have been discussions about expanding the scope to include further investigation concerning conflicts of interest that may have existed with Hidalgo County Drainage District No. 1 and Integ Corporation. Recently, I sent a proposed "template" concerning the possible distinction of the scope of work. I have not received confirmation that it was acceptable. Notwithstanding, if it is acceptable and should be included in an "Amended Letter of Engagement for Legal Services" we will do so. However, it will require additional time to complete. I will have my report concerning my original work assignment to the Hidalgo County Drainage District No. 1 Board on or before May 19, 2015 as set out in the "Amended Letter of Engagement for Legal Services".

Let me hear from you.

Yours very truly,

Michael S. Lee

MSL/cm

SATELLITE OFFICES - BY APPOINTMENT ONLY
AUSTIN • GOLIAD • KENEDY

Martha Salazar
April 29, 2015
Page 2

cc: Evangelina Garcia
Via E-mail – evangelina.garcia@co.hidalgo.tx.us

Darlene H. Bentancourt
Via E-mail – darlene.bentancourt@co.hidalgo.tx.us

Ramon Garcia
Via E-mail – paguilar@ramongarcia-law.com

Cynthia Castro
Via E-mail – Cynthia.castro@co.hidalgo.tx.us

Zimbra

evangelina.garcia@co.hidalgo.tx.us

HCDD1-14-140-06-004-VYG

From : The Lee Firm PC <TheLeeFirmPC@theleefirm.com>

Thu, Apr 30, 2015 05:03 PM

Subject : HCDD1-14-140-06-004-VYG 1 attachment**To** : 'Martha Salazar' <martha.salazar@co.hidalgo.tx.us>**Cc** : 'Evangelina Garcia' <evangelina.garcia@co.hidalgo.tx.us>, cynthia castro <cynthia.castro@co.hidalgo.tx.us>, paguilar@ramongarcia-law.com, 'Darlene H. Betancourt' <darlene.betancourt@co.hidalgo.tx.us>**Re:** HCDD1-14-140-06-004-VYG

Ms. Salazar:

Attached please find the "Amended Letter of Engagement for Legal Services" dated April 30, 2015 in relation to RFQ No. HCDD1-14-140-06-04-VYG; Professional Legal Service in connection with the review and report for the agreement between Hidalgo County Drainage District No. 1 and Integ Corporation.

Michael S. Lee
The Lee Firm, A Professional Corporation
615 N. Upper Broadway, Suite 708
Corpus Christi, Texas 78401
Telephone: 361.882.4444
Facsimile: 361.882.7844
E-mail Reply to: theleefirmpc@theleefirm.com

 **AMENDED LETTER OF ENGAGEMENT FOR LEGAL SERVICES 04-30-15.pdf**
245 KB

AMENDED LETTER OF ENGAGEMENT FOR LEGAL SERVICES

RFQ No: HCDD1-14-140-06-04-VYG

Professional Legal Service in connection with the review and report for the agreement between Hidalgo County Drainage District No. 1 and Integ Corporation

This Agreement is made by and between Michael S. Lee/The Lee Firm, A Professional Corporation (“Attorney”), and Hidalgo County Drainage District No. 1 (“Client”) to review and report for the agreement between Hidalgo County Drainage District No. 1 and Integ Corporation.

1. Scope of Services.

A. Contract Analysis.

The Attorney will provide legal services as requested by Client and accepted by Attorney on a case-by-case and matter-by-matter assignment. Attorney shall provide those legal services reasonably required to represent Client, and shall keep Client informed of the progress of the case or matter. In order to enable Attorney to render effective legal services, Client shall provide all facts and keep Attorney informed of all developments relating to the matter. Attorney must rely on the accuracy and completeness of the facts and information provided by Client. In addition, Attorney will provide legal services in reviewing all documents related to the contractual issues between Hidalgo County Drainage District No. 1 and Integ Corporation; review appropriate Texas case law, whether statutory and/or common law; conferences and meetings with Hidalgo County Drainage District No. 1 representatives; interviews and conferences with any subcontractors and/or other contractors involved in the project developments that are the subject of the issues between Hidalgo County Drainage District No. 1 and Integ Corporation; interview witnesses; provide appropriate legal opinions relating to same. **Due Date: On or Before May 19, 2015.**

B. Investigation/Conflict of Interest.

In 2014 the Hidalgo County Drainage District (District) retained The Lee Firm, A Professional Corporation (The Lee Firm) to investigate and evaluate the contract that was entered into between Integ Corporation (Integ) and the District as it related to compensation paid to Integ, related to the Hidalgo County Master Drainage System Phase II and the federal Border Infrastructure Improvement Project. Currently, The Lee Firm has been working within that scope guidelines. However, the District wishes to amend the scope of the contract between itself and The Lee Firm. The District requests The Lee Firm to expand the scope of its professional evaluation and to analyze any potential conflicts of interests related to Integ, Godfrey Garza and the District as well as contractors who had contracted with the District. As a result, the District authorizes The Lee Firm to file a Petition to Investigate under Texas Rule of Civil Procedure 202 in order to request a Presiding Judge that the District be allowed to take depositions under oath and gather facts and evidence through such discovery in order to determine whether or not there are in fact potential conflicts. The District requests The Lee Firm to investigate any potential conflicts of interest involving any contract or subcontracts related to both the District, more specifically Hidalgo County Master Drainage System Phase II, as well as the federal Border Infrastructure Improvement Project. If the Presiding Judge will allow such investigate discovery to proceed forward, The Lee Firm will do such and will provide the District with any analysis of any conflicts of interest revealed by its discovery and investigation. **Due Date: On or Before August 15, 2015.**

2. Fees. Hourly fees for legal services are based on the amount of time each lawyer or paralegal spends working on the Client’s behalf multiplied by their respective hourly rate. Hourly rates vary among professionals depending on experience, level of expertise and market conditions. Hourly

rates are reviewed annually and will be adjusted only with the Client's written consent. The fee structure accepted for this matter is stated in the attached Exhibit "A". Lead counsel and all attorneys and legal staff working on the assigned matter shall be identified in the attached fee structure.

3. Expenses. By engaging services from Attorney, Client authorizes third-party contracting necessary for representation on Client's behalf and such costs shall be reimbursed for actual costs as incurred as per schedule of costs attached as Exhibit "A", although this list may not be all inclusive. The Attorney will seek approval from Client for any individual expenses that are expected to exceed the sum of \$500.00. Attorney shall also obtain Client's consent before retaining an outside investigator, consultant or expert witness.
4. Billing. The Client shall be billed monthly for fees, costs and expenses incurred (detailed in the attached Exhibit "A") and will reimburse firm for actual expenses incurred in connection with litigation. The Client shall also pay for the time the Attorney spends traveling, (when necessary). Hourly and/or timed billing shall be submitted in increments of one-tenth (1/10th) of an hour. No block billing shall be accepted. Each billing entry shall separately itemize the activity or task performed and the amount of corresponding time. All billing invoices are subject to review by the County Auditor as provided for under the Texas Local Government Code. Payment of billing invoices requires approval by the Hidalgo County Drainage District No. 1.
5. Termination. This agreement will terminate once the case or matter assigned is completely resolved/dismissed, or in the event the Client chooses to terminate the agreement in advance of completion, resolution or final dismissal of the matter, then upon written notice of termination. The term of service of the original Letter of Engagement for Legal Services commenced on October 13, 2014 and expires on February 20, 2015. Due to the new requested scope, Attorney requests an extension which results in the expiration date being August 15, 2015.
6. Client approval is necessary for settlement. Attorney is authorized to engage in settlement negotiations if and when appropriate in their professional judgment. No settlement of any nature shall be made for any of the claims or causes of action of Client without the complete approval of Client. Upon Client approval, Attorney shall have full authority to sign papers or documents regarding settlement. This provision is subject to the terms and conditions of the policy of insurance that indemnifies Client for the claims in the above matter.
7. The Hidalgo County Drainage District No. 1 accepts and approves of Attorney's Professional Liability Insurance with the limits of \$500,000.00.
8. Entire Agreement. This Agreement contains the entire understanding and agreement between the parties with respect to its subject matter (*i.e.*, the review and report for the agreement between Hidalgo County Drainage District No. 1 and Integ Corporation) and supersedes any prior or contemporaneous written or oral agreements, representations or warranties between the parties herein.
9. Amendment. This Agreement may be amended only by written amendment with the approval of the Hidalgo County Drainage District No. 1 and their duly authorized agent or representative.
10. Governing Law. This Agreement shall be construed in accordance with the laws of the State of Texas which law shall govern any actions arising hereunder. Any dispute arising hereunder shall be brought before a court of competent jurisdiction in Hidalgo County, Texas.

AGREED:

LAW FIRM:

The Lee Firm, A Professional Corporation

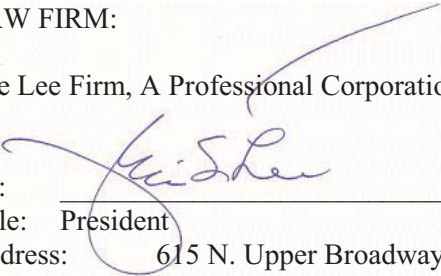
By: 
Title: President

Address: 615 N. Upper Broadway, Suite 708
Corpus Christi, Texas 78401

Telephone: 361.882.4444

Fax: 361.882.7844

E-mail: theleefirmpc@theleefirm.com

Date: April 30, 2015

HIDALGO COUNTY DRAINAGE
DISTRICT NO. 1

By: _____
Title: _____

Address: 2812 S. Business Hwy 281
Edinburg, Texas 78539

Exhibit "A"
**SCHEDULE OF COSTS IN CONNECTION WITH LEGAL REPRESENTATION
INVOLVING HIDALGO COUNTY DRAINAGE DISTRICT NO. 1
AND INTGEG CORPORATION**

Attorney Fees: **Hourly Rate:**
Attorneys: See Attached
Legal Assistant: See Attached

Legal Fees/Court Costs:

Filing Fees	Actual costs
Service of Process & Subpoenas	Actual costs
Mediation Fees	Actual costs
Legal Research Expenses	Actual costs (Lexis Nexis)
Depositions (Court Reporter & Video as appropriate)	Actual costs
Internet Search Fees	Actual costs
Witness Fees	Actual required by law
Expert Witness Fees	Actual costs
Hearing Transcript Fees (as appropriate)	Actual costs
Investigator Fees (as appropriate)	Actual costs

Travel Expenses:

Mileage Rate (IRS guidelines recommended) – Prevailing IRS Rate
Air Travel (most economical travel recommended) – Most economical taking into consideration travel time.
Hotel (most economical recommended – not to exceed \$100.00 per day)
Meals (to be reimbursed only if traveling out of town – not to exceed \$39.00 per day)

Office Expense:

Faxes	\$1.25 per page
Copies	\$.30 per page
Binding	As charged by Texas Star Documents
Telephone (Long Distance only)	As charged by Foremost

Postage and Express Mail:

U.S. Mail	Actual costs
Express Mail	Actual costs
Other:	
Overnight Delivery	Actual costs

Itemized receipts must be provided for each expense.

Send billing to: Hidalgo County Drainage District No. 1
 ATTN: Evangelina Garcia
 Hidalgo County Purchasing Department
 2812 S. Business Hwy. 281
 Edinburg, Texas 78539
 E-mail: Evangelina.garcia@co.hidalgo.tx.us

CHARGES FOR ATTORNEY FEES AND LEGAL ASSISTANT

Michael S. Lee Senior Attorney	\$250.00 per hour
Contract Senior Attorney/Of Counsel	\$250.00 per hour
Contract Junior Attorney/Of Counsel	\$200.00 per hour
Senior Paralegal	\$125.00 per hour
Junior Paralegal	\$100.00 per hour
Investigator	\$100.00 per hour
Administrative Tasks	\$75.00 per hour

AI -49535

6.

DRAINAGE DISTRICT

Meeting Date: 05/05/2015

Submitted By: Claudette Guerrero,
DRAINAGE DISTRICT

Department: DRAINAGE DISTRICT

Information

CAPTION

Request approval to issue manual payment once review and audit procedures are complete on the following items:

A. Request for Payment No. 1 in the amount of \$70,965.00 from Foremost Paving Inc. related to Construction Contract No. HCDD1-14-003-02-05-Pct. 4 West Main Drain. PO#624506.

B. Request for Payment No. 2 in the amount of \$60,525.00 from Foremost Paving Inc. related to Construction Contract No. HCDD1-14-003-02-05-Pct. 4 West Main Drain. PO#624506.

C. Request for Payment No. 3 Final- Retainage Release in the amount of \$24,779.50 from Foremost Paving Inc. related to Construction Contract No. HCDD1-14-027-10-08-HCDD#1-North Main Weir#1. PO#625973.

BACKGROUND

Fiscal Impact

Attachments

Foremost PMT1 WMD

DD1 PE LTR FOREMOST PMT1 WMD

DD1 PE LTR FOREMOST PMT2 WMD

Foremost PMT3 NMW1

DD1 PE LTR FOREMOST PMT3 NMW1

Foremost PMT2-WMD

Form Review

Inbox

Reviewed By

Date

Budget & Management

Veronica Ortiz

05/01/2015 10:34 AM

Final Approval

Monica Badillo

05/01/2015 03:23 PM

Form Started By: Claudette Guerrero

Started On: 04/30/2015 02:52 PM

Final Approval Date: 05/01/2015



2020 E. EXPRESSWAY 83, MERCEDES, TEXAS 78570
 PHONE NO. 565-4637 FAX NO. 565-4636

TO: Hidalgo Co. Drainage District No. 1
Attn: Jaime Salazar
902 N. Doolittle
Edinburg, TX 78542

LETTER OF TRANSMITTAL

Dated: March 6, 2015	Project No. P-790
RE:	
<i>Hidalgo County Drainage District #1</i>	
<i>Existing Weir Modification &</i>	
<i>Existing Concrete Culvert Slide</i>	
<i>Gate Control Structure Imp.</i>	
<i>HCDD1-14-003-02-05</i>	
<i>Pay App. No. 1</i>	
Via: <i>A-FAST</i>	
Tracking # <i>6249</i>	

WE ARE SENDING:

Submittals	Application	Sketch	Letter
Attached	Prints	Drawings	X Pay Application
Change Order	Plans	Disc	Submittals
			Specs

COPIES	DATE	NO.	DESCRIPTION
<i>1</i>	<i>3/6/2015</i>	<i>P790</i>	<i>One (1) Original Copy of Pay App No. 1 for the above referenced project.</i>

THESE ARE TRANSMITTED AS CHECKED BELOW:

<input type="checkbox"/> For approval	<input type="checkbox"/> Approved as submitted	<input type="checkbox"/> Resubmit	<input type="checkbox"/> Copies for approval
<input type="checkbox"/> For your use/info	<input type="checkbox"/> Approved as noted	<input type="checkbox"/> Submit	<input type="checkbox"/> Copies for distribution
<input type="checkbox"/> As requested	<input type="checkbox"/> Returned for corrections	<input type="checkbox"/> Return	<input type="checkbox"/> Correction prints
<input checked="" type="checkbox"/> For review and payment	Other _____		
<input type="checkbox"/> For bids due _____			

REMARKS: Please review, process and approve for payment. Should you have any questions or concerns, please contact our office at (956)565-4637. Thank you.

Received by : _____

SIGNED: *[Signature]*
 GMES Representative

Please fax back signed letter of transmittal at (956) 565-4636.

If enclosures are not as noted, kindly notify us at once.

RECEIVED
 HIDALGO COUNTY
 DRAINAGE DISTRICT #1

MAR 10 2015

4:08 AM/PM
 BY: *Rosa Roca*

APPLICATION AND CERTIFICATE FOR PAYMENT

TO OWNER:

Hidalgo County Drainage District No. 1
902 North Doolittle
Edinburg, Tx 78539

PROJECT:

HCDD #1 Pct #4 Area - West Main Drain
Existing Weir Modification &
Existing Concrete Culvert Slide
Gate Control Structure Imp

APPLICATION #: 1

APPLICATION DATE: 2/27/2015

PERIOD TO: 2/28/2015

PROJECT NO: HCDD-1-14-003-02-05

P.O. NO.:

CONTRACT DATE: 2/11/2014

CONTRACT DAYS: 120

CONTRACT FIRST WORK DAY: 2/13/2015

DISTRIBUTION TO:

<input checked="" type="checkbox"/>	Owner
<input type="checkbox"/>	Const. Man.
<input type="checkbox"/>	Architect
<input type="checkbox"/>	Contractor
<input type="checkbox"/>	Engineer

RECEIVED
HIDALGO COUNTY
DRAINAGE DISTRICT #1

ENGINEER:

Foremost Paving, Inc.
P.O. Box 29
Welaco, Tx 78599

Guzman & Muñoz Engineering
2020 E. Expressway 83
Mercedes, Tx 78570

CONTRACT FOR: HCDD#1 Pct #4 Area - Project West Main Drain Existing Weir Modification & Existing Concrete Culvert Slide Gate Control Structure Improvements

CONTRACTOR'S APPLICATION FOR PAYMENT

Application is made for payment, as shown below, in connection with the contract. Continuation Sheet is Attached

1. Original Contract Sum -----	\$	146,100.00
2. Net Change by Change Orders -----	\$	-
3. Contract Sum to Date (Line 1+/- 2) -----	\$	146,100.00
4. Total Completed & Stored To Date -----	\$	78,850.00
A. Materials on Hand -----	\$	-
5. Retainage -----	\$	7,885.00
a. 10.0% of Completed Work -----	\$	-
b. 10% of Stored Material -----	\$	-
Total in Column O of Continuation Sheet -	\$	70,965.00
6. Total Earned Less Retainage -----	\$	-
7. Less Previous Certificates for Payment -----	\$	70,965.00
8. Current Balance Payment Due -----	\$	67,250.00
9. Balance to Finish, Including Retainage -----	\$	-

The Undersigned Contractor certifies that to the best of the Contractor's knowledge, information and belief the work covered by this Application for Payment has been completed in accordance with the Contract Documents, that all amounts have been paid by the Contractor for work for which previous Certificates for Payment were issued and payments received from the Owner, and that current payments shown therein is now due

CONTRACTOR: Foremost Paving, lbc.

By: [Signature] Date: 3/2/15

State of Texas

County of Hidalgo

Subscribed and Sworn to me before this

Notary Public [Signature]

My Commission Expires: MARCH 19 2018

CERTIFICATE FOR PAYMENT

In accordance with Contract Documents, based on on-site observations and the data comprising application, the Engineer certifies to the best of the Engineer's knowledge, information and belief the Work has progressed as indicated, the quality of the Work is in accordance with the Contract Documents, and the Contractor is entitled to payment of the AMOUNT CERTIFIED

AMOUNT CERTIFIED: \$

(Attach explanation if amount certified differs from the amount applied for. Initial all figures on this application and on the continuation sheet that are changed to conform to the amount certified)

ADDITIONS

DEDUCTIONS

Engineer: Guzman & Muñoz Engineering

By: [Signature]

Date: 3/2/15

CHANGE ORDER SUMMARY	ADDITIONS	DEDUCTIONS
Total changes approved in previous months by owner	\$0.00	\$0.00
total approved this month	\$0.00	\$0.00
Totals	\$0.00	\$0.00

NET CHANGES by Change orders

This Certified is not negotiable. The AMOUNT CERTIFIED is payable only to the Contractor name herein. Issuance, payment and acceptance of payment are without prejudice to any rights of the owner of contractor under this Contract

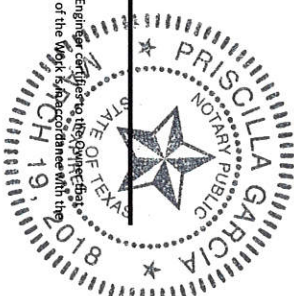

4:08 AM PM
BY Rosa Diaz
MAR 10 2015

Contractor:

From: Foremost Paving, Inc.
 P. O. Box 29
 Weslaco, TX 78599

Project No. HCCD-1-14-003-02-05
 Description HCCD #1 Hidalgo Co. Pct #4 Area - Project West Main Drain Existing Weir
 Modification & Existing Concrete Culvert Slide Gate Control Structure Improvements

Subcontractor To: Hidalgo County Drainage District No. 1
 902 North Doolittle
 Edinburg, TX 78539

Period: Feb-15
 Pay Request: 1
 Date: 02/27/2015

Item No.	Item Description	Unit of Measure	Original Contract Quantity	Revised Contract Quantity	Quantity Completed to Date	Unit Price	Item Total Cost	Revised Item Total Cost	Change in Contract Cost	Amount of Completed Work
1	Modify Existing Concrete Weir as per plans and specifications	LS	1	1	0	\$60,000.00	\$60,000.00	\$60,000.00	\$0.00	\$0.00
2	By Pass Pumping for the entire project	LS	1	1	0	\$100.00	\$100.00	\$100.00	\$0.00	\$0.00
Alternate 1										
3	Furnish & install 10' X 10' Stainless Steel Slide Gate with installation as per plans and specifications, complete in place	Ea	1	1	0.95	\$83,000.00	\$83,000.00	\$83,000.00	\$0.00	\$78,850.00
4	Gasoline Power Portable Actuator for Slide Gate	Ea	1	1	0	\$3,000.00	\$3,000.00	\$3,000.00	\$0.00	\$0.00
	Materials On Hand					Subtotal	\$146,100.00	\$146,100.00	\$0.00	\$78,850.00
						Subtotal	\$0.00	\$0.00		\$0.00
TOTALS							\$146,100.00	\$146,100.00	\$0.00	\$78,850.00

Submitted:	Original Amount of Contract:	\$146,100.00
(Contractor)	Approved Change Orders	\$0.00
Recommended:	Total Amount of Contract:	\$146,100.00
(Engineer)	Total Amount of Work Completed:	\$78,850.00
Approval:	Less Amount Retained:	\$7,885.00
(Owner)	Net Amount Due on Contract:	\$70,965.00
	Less Amount of Previous Payments:	\$0.00
	Balance Due This Estimate:	\$70,965.00



**HIDALGO COUNTY
DRAINAGE
DISTRICT No. 1**

RAUL E. SESIN, PE, CFM
General Manager
Floodplain Administrator

902 N. Doolittle Road
Edinburg, Texas 78542
Off 956 292.7080
Fax 956 292.7089

BOARD OF DIRECTORS

RAMON GARCIA
Chairman of the Board

A.C. CUELLAR, JR.
Board Member

EDUARDO "EDDIE" CANTU
Board Member

JOE M. FLORES
Board Member

JOSEPH PALACIOS
Board Member

April 29, 2015

Lora Briones
Financial Officer
Re: Invoice

*JB
4-29-2015*

- 1.) Foremost Paving Inc. / Guzman & Munoz** *624504*
Invoice # Application #1 / 3-2-2015 / \$70,965.00
- 2.) Foremost Paving Inc. / Guzman & Munoz**
Invoice # Application #2 / 3-23-2015 / \$60,525.00
- 3.) Foremost Paving Inc. / Guzman & Munoz**
Invoice # Application Retainage / 3-23-2015 / \$14,610.00

I have reviewed the invoice referenced above, and have no issues for payment based on the back up information and complete percentages they are billing the Drainage District. Should you have any questions, please feel free to contact me.

Thank you,

J. Noe Saldivar, P.E.
J. Noe Saldivar. P.E.
Hydraulic Engineer

Date: *4/29/15* Time: *9:00 AM*

Cc: Raul E. Sesin, PE, CFM



**HIDALGO COUNTY
DRAINAGE
DISTRICT No. 1**

RAUL E. SESIN, PE, CFM
General Manager
Floodplain Administrator

902 N. Doolittle Road
Edinburg, Texas 78542
Off 956 292.7080
Fax 956 292.7089

BOARD OF DIRECTORS

RAMON GARCIA
Chairman of the Board

A.C. CUELLAR, JR.
Board Member

EDUARDO "EDDIE" CANTU
Board Member

JOE M. FLORES
Board Member

JOSEPH PALACIOS
Board Member

April 29, 2015

Lora Briones
Financial Officer
Re: Invoice

*JB
4-29-2015*

- 1.) Foremost Paving Inc. / Guzman & Munoz** *624504*
Invoice # Application #1 / 3-2-2015 / \$70,965.00
- 2.) Foremost Paving Inc. / Guzman & Munoz**
Invoice # Application #2 / 3-23-2015 / \$60,525.00
- 3.) Foremost Paving Inc. / Guzman & Munoz**
Invoice # Application Retainage / 3-23-2015 / \$14,610.00

I have reviewed the invoice referenced above, and have no issues for payment based on the back up information and complete percentages they are billing the Drainage District. Should you have any questions, please feel free to contact me.

Thank you,

J. Noe Saldivar, P.E.
J. Noe Saldivar. P.E.
Hydraulic Engineer

Date: *4/29/15* Time: *9:00 AM*

Cc: Raul E. Sesin, PE, CFM



5000 West Military, Ste 100
McAllen, Texas 78503
(956) 664-0286
Fax (956) 664-0282

LETTER OF TRANSMITTAL

To: Jaime Salazar
Hidalgo County Drainage District No. 1
From: Courtney M. Villarreal
Administrative Assistant
Email: cvillarreal@halff.com

Date: February 5, 2015
AVO: 29945
North Main Drain Weir
No. 1

WE ARE SENDING YOU Attached Under separate cover via ___ the following:

Shop Drawings Prints Plans Drawings Specifications

Copy of letter Report(s) CD/DVD Other: _____

VIA: Hand Delivery US Postal Service Courier Overnight Express

THESE ARE TRANSMITTED as checked below:

For approval Approval as submitted Resubmit ___ copies for approval
 For your use Approved as noted Submit ___ copies for distribution
 As requested Returned for corrections Return ___ corrected prints
 For review/comment Other: _____

ITEMS SENT:

- 1 – Original Pay Application No.2 for Foremost Paving Inc.'s January 2015 Invoice
- 1 – Original Pay Application No.3 for Foremost Paving Inc.'s Retainage
- 2 – Sets of Record Drawings
- 1 – Contract Closeout Letter

COMMENTS:

RECEIVED
HIDALGO COUNTY
DRAINAGE DISTRICT #1

FEB 05 2015

SIGNED: Courtney M. Villarreal

_____ AM / PM

BY: _____

Signed: *Jaime Salazar* Date: 2-5-15 Time: 4:22pm

COPIES:

File Owner Contractor Other:



February 5, 2015
AVO 29945

Godfrey Garza
Manager
Hidalgo County Drainage District No. 1
902 N. Doolittle
Edinburg, Texas 78542

Re: RFB No. HCDD1-14-027-10-08 – North Main Drain Weir No. 1

Dear Mr. Garza:

This letter is to inform you that all improvements for the North Main Drain Weir No. 1 have been completed and are in general conformance with the contract documents.

The improvements for the project were constructed by Foremost Paving, Inc. We carried out a final inspection of the site on Thursday, February 5, 2015 and all punchlist items have been addressed.

If you have any questions or comments, please feel free to contact our office.

Halff Associates, Inc.

A handwritten signature in blue ink, appearing to read "Raul Garcia Jr.", written over a light blue horizontal line.

Raul Garcia Jr, PE, CFM
Senior Project Manager

HIDALGO COUNTY DRAINAGE DISTRICT NUMBER ONE

902 NORTH DOOLITTLE

EDINBURG, TEXAS 78542

(958) 292-7080

FAX (958) 292-7089



GODFREY GARZA, JR.
MANAGER

INVOICE PROCESSING CHECKLIST

Data Received: 02/16/2015

Engineer/Firm Name: HALFF ASS.

Project Name/Number: N. Main Weir #1

Invoice No: Application #3

Logged in and Scanned: 4:22 PM By: Rosa Arce Forwarded to: Joey Garza

Engineer	Name	Date	Comment
Scope of work reviewed			

Accounting	Name	Date	Comment
Encumbrance			
Purchase Order Attached			
Audit			
Final Approval for Agenda			

	Name	Date	Comment
Placed on Agenda			

Additional Comments: _____



FOREMOST PAVING, INC.

P.O. BOX 29 WESLACO, TEXAS 78599-0029

January 28, 2015

Mr. Raul Garcia, Jr. P.E.
Half Associates, Inc.
5000 West Military Suite 100
McAllen, Tx 78503

Re: Civil Site Improvements For HCDD No. 1- North Main Drain Weir No. 1
Retainage Invoice

Dear Mr. Garcia,

Enclosed please find the Retainage invoice for the above-mentioned project. Please process for payment at your earliest convenience.

If I can be of additional service, please feel free to call me.

Sincerely,

A handwritten signature in black ink, appearing to read 'Juan Galvan', is written over the word 'Sincerely,'. The signature is stylized with loops and a long horizontal stroke.

Juan Galvan

APPLICATION AND CERTIFICATE FOR PAYMENT

TO OWNER: Hidalgo County Drainage District No. 1
 902 North Doolittle
 Edinburg, Tx 78539

FROM CONTRACTOR: Foremost Paving, Inc.
 P.O. Box 29
 Welaco, Tx 78599

PROJECT: Civil Site Improvements for HCDD #1 - North Main Weir #1

ENGINEER: Half Associates, Inc.
 5000 West Military STE 100
 McAllen, Tx 78503

APPLICATION #: 3

APPLICATION DATE: 1/28/2015

PERIOD TO: 1/31/2015

PROJECT NO.: HCDD1-14-027-10-08

P.O. NO.:

CONTRACT DATE: 10/16/2014

CONTRACT DAYS: 90

CONTRACT FIRST WORK DAY: 12/9/2014

DISTRIBUITION TO:

<input checked="" type="checkbox"/>	Owner
<input type="checkbox"/>	Const. Man.
<input type="checkbox"/>	Architect
<input type="checkbox"/>	Contractor
<input type="checkbox"/>	Engineer

RECEIVED
 HIDALGO COUNTY
 DRAINAGE DISTRICT #1
 FEB 05 2015
 4:22 AM

BY: Esther Layton

CONTRACTOR'S APPLICATION FOR PAYMENT

Application is made for payment, as shown below, in connection with the contract. Continuation Sheet is Attached

1. Original Contract Sum -----	\$ 247,795.00
2. Net Change by Change Orders -----	\$ -
3. Contract Sum to Date (Line 1+/- 2) -----	\$ 247,795.00
4. Total Completed & Stored To Date -----	\$ 247,795.00
A. Materials on Hand -----	\$ -
5. Retainage -----	\$ -
a. 0.0% of Completed Work -----	\$ -
b. 10% of Stored Material -----	\$ -
Total In Column O of Continuation Sheet -	\$ 247,795.00
6. Total Earned Less Retainage -----	\$ 247,795.00
7. Less Previous Certificates for Payment -----	\$ 223,015.50
8. Current Balance Payment Due -----	\$ 24,779.50
9. Balance to Finish, Including Retainage -----	\$ -

The undersigned Contractor certifies that to the best of the Contractor's knowledge, information and belief the work covered by this Application for Payment has been completed in accordance with the Contract Documents, that all amounts have been paid by the Contractor for work for which previous Certificates for Payment were issued and payments received from the Owner, and that current payment shown therein is now due

CONTRACTOR: Foremost Paving, Inc. Date: 1/28/2015

By: [Signature]

State of Texas

County of Hidalgo

Subscribed and Sworn and sworn to before me to me before this 28th Day of January 2015

Notary Public [Signature]

My Commission Expires: March 19, 2018



CERTIFICATE FOR PAYMENT

In accordance with Contract Documents, based on on-site observations and the data comprising application, the Engineer certifies to the Owner that to the best of the Engineer's knowledge, information and belief the Work has progressed as indicated, the quality of the Work is of Good and that the Contract Documents, and the Contractor is entitled to payment of the AMOUNT CERTIFIED

AMOUNT CERTIFIED --- \$ 24,779.50

(Attach explanation if amount certified differs from the amount applied for. Initial all figures on this application and on the continuation sheet that are changed to conform to the amount certified)

CHANGE ORDER SUMMARY	ADDITIONS	DEDUCTIONS
Total changes approved in previous months by owner	\$0.00	\$0.00
total approved this month	\$0.00	\$0.00
Totals	\$0.00	\$0.00
NET CHANGES by Change orders		

Engineer: Half Associates, Inc.

By: [Signature]

Date: 2/5/15

This Certificate is not negotiable. The AMOUNT CERTIFIED is payable only to the Contractor name herein. Issuance, payment and acceptance of payment are without prejudice to any rights of the owner of contractor under this Contract

--	--	--	--	--	--	--	--	--	--	--

TOTALS										

Submitted:

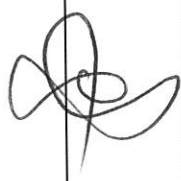

(Contractor)

Recommended:

(Engineer)

Approval:

(Owner)

Original Amount of Contract:		\$247,795.00
Approved Change Orders	\$0.00	
Total Amount of Contract:	\$247,795.00	
Total Amount of Work Completed:	\$247,795.00	
Less Amount Retained:	0%	\$0.00
Net Amount Due on Contract:	\$247,795.00	
Less Amount of Previous Billings:	\$223,015.50	
Balance Due This Estimate:	\$24,779.50	

HIDALGO COUNTY DRAINAGE DISTRICT NUMBER ONE

902 NORTH DOOLITTLE

EDINBURG, TEXAS 78542

(956) 292-7080

FAX (956) 292-7089



GODFREY GARZA, JR., C.F.M.
DISTRICT MANAGER

February 23, 2015

Lora Briones
Financial Officer
Re: Invoice

1.) Foremost Paving, Inc. / Inv. # Application #3 / 01-28-2015 / \$24,779.50

I have reviewed the invoice referenced above, and have no issues for payment based on the information, and complete percentages they are billing the Drainage District. If you should have any questions, please feel free to contact our office.

Thank you,

J. Noe Saldivar, P.E.

Hydraulic Engineer

Date: 02/23/15 Time: 3:40 PM

Cc: Raul E. Sesin, PE, CFM

*Reviewed
04/28/15
JRS*

*LB
4-28-2015*

*LB
2/23/2015*



2020 E. EXPRESSWAY 83, MERCEDES, TEXAS 78570
 PHONE NO. 565-4637 FAX NO. 565-4636

LETTER OF TRANSMITTAL

Dated: April 7, 2015	Project No. P-790-05
RE:	
<i>Hidalgo County Drainage District #1 Pct #4</i>	
<i>Existing Weir Modification &</i>	
<i>Existing Concrete Culvert Slide</i>	
<i>Gate Control Structure Imp.</i>	
<i>HCDD1-14-003-02-05</i>	
<i>"Closing Documents"</i>	
Via: Hand Delivered	
Tracking #	

TO: Hidalgo Co. Drainage District No. 1
Attn: Raul Sesin
902 N. Doolittle
Edinburg, TX 78542

WE ARE SENDING:

Submittals	Application	Sketch	X Letter
Attached	Drawings	Final Plat	X Pay Application
Change Order	X Plans	Disc	X Submittals
			X Release of Lien

COPIES	DATE	NO.	DESCRIPTION
1	4/7/2015	P790-05	One (1) Original Copy of Letter Submitting Retainage Invoice for the above referenced project.
1	4/7/2015	P790-05	One (1) Original Copy of Retainage Application for the above referenced project.
1	4/7/2015	P790-05	One (1) Original Copy of Letter Submitting March Estimates for the above referenced project.
1	4/7/2015	P790-05	One (1) Original Copy of Pay App. 2 for the above referenced project.
1	4/7/2015	P790-05	One (1) Original Copy of Contractor's Affidavit of Release of Liens.
1	4/7/2015	P790-05	One (1) Original Copy of Contractor's Affidavit of Payment of Debts and Claims.
1	4/7/2015	P790-05	One (1) Copy of Unconditional Waiver and Release on Final Payment.
1	4/7/2015	P790-05	One (1) Copy of Partial Release of Lien and Claim for the above referenced project.
1	4/7/2015	P790-05	One (1) Copy Submittal for Slidegate & Operator for the above referenced project.
1	4/7/2015	P790-05	One (1) Set of Record Drawing Plans for the above referenced project.

THESE ARE TRANSMITTED AS CHECKED BELOW:

For approval _____ Approved as submitted _____ Resubmit _____ Copies for approval

Final approval _____ Approved as noted _____ Submit _____ Copies for distribution

_____ As requested _____ Returned for corrections _____ Return _____ Correction prints

For review and payment _____ Other _____

_____ For bids due _____

REMARKS: Please review and process for final approval. Should you have any questions or concerns, please contact our office at (956)565-4637. Thank you.

Received by : _____

SIGNED: [Signature]
 GMES Representative

*PLEASE FAX BACK TO:
 (956) 565-4636*

*Reviewed
 Submitted for
 Slidegate &
 operator.*

RECEIVED
 HIDALGO COUNTY
 DRAINAGE DISTRICT #1

APR 14 2015

9:51 AM PM

BY: Rosadice



2020 E. EXPRESSWAY 83, MERCEDES, TEXAS 78570
 PHONE NO. 565-4637 FAX NO. 565-4636

LETTER OF TRANSMITTAL

Dated: April 7, 2015	Project No. P-790-05
RE:	
<i>Hidalgo County Drainage District #1 Pct #4</i>	
<i>Existing Weir Modification &</i>	
<i>Existing Concrete Culvert Slide</i>	
<i>Gate Control Structure Imp.</i>	
<i>HCDD1-14-003-02-05</i>	
<i>"Closing Documents"</i>	
Via: Hand Delivered	
Tracking #	

TO: Hidalgo Co. Drainage District No. 1
Attn: Raul Sesin
902 N. Doolittle
Edinburg, TX 78542

WE ARE SENDING: Submittals Application Sketch **X Letter**

Attached Prints Drawings Final Plat **X Pay Application**

Change Order **X Plans** Disc **X Submittals** **X Release of Lien**

COPIES	DATE	NO.	DESCRIPTION
1	4/7/2015	P790-05	One (1) Original Copy of Letter Submitting Retainage Invoice for the above referenced project.
1	4/7/2015	P790-05	One (1) Original Copy of Retainage Application for the above referenced project.
1	4/7/2015	P790-05	One (1) Original Copy of Letter Submitting March Estimates for the above referenced project.
1	4/7/2015	P790-05	One (1) Original Copy of Pay App. 2 for the above referenced project.
1	4/7/2015	P790-05	One (1) Original Copy of Contractor's Affidavit of Release of Liens.
1	4/7/2015	P790-05	One (1) Original Copy of Contractor's Affidavit of Payment of Debts and Claims.
1	4/7/2015	P790-05	One (1) Copy of Unconditional Waiver and Release on Final Payment.
1	4/7/2015	P790-05	One (1) Copy of Partial Release of Lien and Claim for the above referenced project.
1	4/7/2015	P790-05	One (1) Copy Submittal for Slidegate & Operator for the above referenced project.
1	4/7/2015	P790-05	One (1) Set of Record Drawing Plans for the above referenced project.

THESE ARE TRANSMITTED AS CHECKED BELOW:

For approval _____ Approved as submitted _____ Resubmit _____ Copies for approval

Final approval _____ Approved as noted _____ Submit _____ Copies for distribution

_____ As requested _____ Returned for corrections _____ Return _____ Correction prints

For review and payment Other _____

_____ For bids due _____

REMARKS: Please review and process for final approval. Should you have any questions or concerns, please contact our office at (956)565-4637. Thank you.

Received by : _____

SIGNED: *Rosa Arce*
 GMES Representative

If enclosures are not as noted, kindly notify us at once.

RECEIVED
 HIDALGO COUNTY
 DRAINAGE DISTRICT #1

APR 14 2015
 9:51 AM PM
 BY: Rosa Arce



P.O. Box 530402
Harlingen, Texas 78553

425-7333 866-31A-FAST 425-7335
425-3075 FAX

CONTROL NUMBER
9671

DATE 4-14-15

BILL SHIPPER THIRD PARTY BILLING FREIGHT COLLECT SCHEDULED HOT SHOT (2 hrs.)
 BILL RECIPIENT PAID IN ADVANCE COLLECT C.O.D. ONLY REGULAR (4 hrs.) EXCLUSIVE (1 hr. + -)

SHIPPER <u>Guzman & Munoz</u>		CONSIGNEE <u>Hidalgo Co. Drainage</u>	
ADDRESS		ADDRESS <u>902 N. D. Little</u>	
CITY <u>Mercedes</u>	PHONE NUMBER	CITY <u>Edinburg</u>	PHONE NUMBER
REQUESTOR		ATTENTION	

NO. PCS	PACKAGING-DESCRIPTION-MARKS	WEIGHT	AMOUNT
1	roll		DELIVERY CHARGE
1	envelope		DETENTION CHARGE
			C.O.D. AMOUNT
			C.O.D. CHARGE
Not Responsible For Freight Claims after 72 Hours		\$50 Declared Value	Insurance Charge
Not Responsible For Concealed Damage		Unless Specified Here \$ _____	.50 per \$100
DRIVER NUMBERS	PICK UP & DELIVERY TIME	SHIPPED BY	TOTAL CHARGES
#1 <u>111</u>	#2 <u>508</u>	<u>Rosa Arce</u>	
		RECEIVED BY	
		PRINT NAME <u>Rosa Arce</u>	

ROSA ARCE 4-14-15

Invoice #1 - Application # Retainage
 #2 - Application # 2
 - West main Drain Existing Weir
 Modifications & Existing Concrete
 Culvert Slide

White-Original Yellow-Duplicate Pink-Consignee Gold-Shipper



Hidalgo County Drainage District No. 1

902 North Doolittle Road Edinburg, Texas 78542 Office: (956) 292-7080 Fax: (956) 292-7089

Invoice Processing Checklist

Date Received: 4-14-15

Engineer/Firm Name: Foremost Paving Inc. / Guzman & Monoz

Project Name/Number: West Main Drain Existing Weir Mod...

Invoice No.: Application # Retainage

Purchase Order No.: _____

Received By: Rosa Arce

Forwarded to: Joey Garza

Total # of Pages Submitted: 42 Pages (As submitted)

Attachments: CD: _____ USB: _____ Other: Plans N/A: _____

Additional Comments:

(2) Invoice's submitted together # of pages includes both invoices (As submitted)



FOREMOST PAVING, INC.

P.O. BOX 29 WESLACO, TEXAS 78599-0029

March 23, 2015

Mr. Jose Luis Muniz., P.E.
Guzman & Muñoz Engineering & Surveying Inc.
2020 E. Expressway 83.
Mercedes, Texas 78570

Re: HCDD #1 Pct No. 4 Area – West Main Drain Existing Weir Modification & Existing Concrete Culvert Slide Gate Control Structure Improvements Retainage Invoice

Dear Mr. Muniz,

Enclosed is the Retainage Invoice for the above-mentioned project.

Please process for payment at your earliest convenience.

If I can be of additional service, please feel free to contact me.

Sincerely,

Juan Galvan

Roxanne
Need for Jose to sign
both.
Witting on
Release of Liens
Waiver of Liens
and final walk thru
Meeting and confirm
JL Muniz

APPLICATION AND CERTIFICATE FOR PAYMENT

TO OWNER:
 Hidalgo County Drainage District No. 1
 902 North Doolittle
 Edinburg, Tx 78539

PROJECT:
 HCDD #1 Pct #4 Area-West Main Drain
 Existing Weir Modification &
 Existing Concrete Culvert Slide
 Gate Control Structure Imp

APPLICATION #: Retainage

DISTRIBUTION TO:

<input checked="" type="checkbox"/>	Owner
<input type="checkbox"/>	Const. Man.
<input type="checkbox"/>	Architect
<input type="checkbox"/>	Contractor
<input type="checkbox"/>	Engineer

RECEIVED
 HIDALGO COUNTY
 DRAINAGE DISTRICT #1

FROM CONTRACTOR:
 Foremost Paving, Inc.
 P.O. Box 29
 Welaco, Tx 78599

ENGINEER:

Guzman & Muñoz Engineering
 2020 E. Expressway 83
 Mercedes, Tx 78570

CONTRACT FIRST WORK DAY: 2/13/2015

CONTRACT FOR: HCDD#1 Pct #4 Area - Project West Main Drain Existing Weir Modification & Existing Concrete Culvert Slide Gate Control
 Structure Improvements

APR 14 2015
 9:51 AM / PM
 BY: Rosa Arce

CONTRACTOR'S APPLICATION FOR PAYMENT

Application is made for payment, as shown below, in connection with the contract. Continuation Sheet is Attached

1. Original Contract Sum -----	\$	146,100.00
2. Net Change by Change Orders -----	\$	-
3. Contract Sum to Date (Line 1+/- 2) -----	\$	146,100.00
4. Total Completed & Stored To Date -----	\$	146,100.00
A. Materials on Hand -----	\$	-
5. Retainage -----	\$	-
a. 0.0% of Completed Work -----	\$	-
b. 10% of Stored Material -----	\$	-
Total In Column O of Continuation Sheet -	\$	146,100.00
6. Total Earned Less Retainage -----	\$	131,490.00
7. Less Previous Certificates for Payment -----	\$	14,610.00
8. Current Balance Payment Due -----	\$	-
9. Balance to Finish, Including Retainage	\$	-

The Undersigned Contractor certifies that to the best of the Contractor's knowledge, information and belief the work covered by this Application for Payment has been completed in accordance with the Contract Documents, that all amounts have been paid by the Contractor for work for which previous Certificates for Payment were issued and payments received from the Owner, and that current payment shown therein is now due

CONTRACTOR: Foremost Paving, lbc.
 By: [Signature] Date: 3/23/15
 State of Texas
 County of Hidalgo
 Subscribed and Sworn to me before this [Signature] 3/23/15
 Notary Public
 My Commission Expires: March 19, 2018

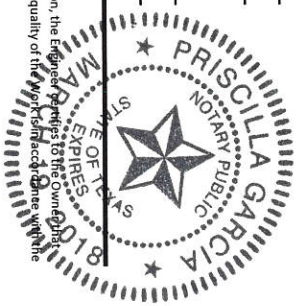

CERTIFICATE FOR PAYMENT
 In accordance with Contract Documents, based on on-site observations and the data comprising application, the Engineer certifies to the best of the Engineer's knowledge, information and belief the Work has progressed as indicated, the quality of the Work is in accordance with the Contract Documents, and the Contractor is entitled to payment of the AMOUNT CERTIFIED
AMOUNT CERTIFIED-----\$ 14,610.00

(Attach explanation if amount certified differs from the amount applied for. Initial all figures on this application and on the continuation sheet that are changed to conform to the amount certified)

CHANGE ORDER SUMMARY	ADDITIONS	DEDUCTIONS
Total changes approved in previous months by owner	\$0.00	\$0.00
Total approved this month	\$0.00	\$0.00
Totals	\$0.00	\$0.00
NET CHANGES by Change orders		

Engineer: Guzman & Muñoz Engineering
 By: [Signature] Date: 3/23/15

This Certified is not negotiable. The AMOUNT CERTIFIED is payable only to the Contractor name herein. Issuance, payment and acceptance of payment are without prejudice to any rights of the owner of contractor under this Contract

Contractor:

From: Foremost Paving, Inc.
 P.O. Box 29
 Westlaco, TX 79699

Project No. HCDD1-14-003-02-05
 Description HCDD #1 Hidalgo Co. Pct #4 Area - Project West Main Drain Existing Weir
 Modification & Existing Concrete Culvert Slide Gate Control Structure Improvements

Subcontractor To: Hidalgo County Drainage District No. 1
 902 North Doolittle
 Edinburg, TX 78539

Period: Mar-15
 Pay Request: Retainage
 Date: 03/23/2015

Item No.	Item Description	Unit of Measure	Original Contract Quantity	Revised Contract Quantity	Quantity Completed to Date	Unit Price	Item Total Cost	Revised Item Total Cost	Change in Contract Cost	Amount of Completed Work
1	Modify Existing Concrete Weir as per plans and specifications	LS	1	1	1	\$60,000.00	\$60,000.00	\$60,000.00	\$0.00	\$60,000.00
2	By Pass Pumping for the entire project	LS	1	1	1	\$100.00	\$100.00	\$100.00	\$0.00	\$100.00
Alternate 1										
3	Furnish & Install 10' X 10' Stainless Steel Slide Gate with installation as per plans and specifications, complete in place	Ea	1	1	1	\$83,000.00	\$83,000.00	\$83,000.00	\$0.00	\$83,000.00
4	Gasoline Power Potable Actuator for Slide Gate	Ea	1	1	1	\$3,000.00	\$3,000.00	\$3,000.00	\$0.00	\$3,000.00
	Materials On Hand						\$146,100.00	\$146,100.00	\$0.00	\$146,100.00
							Subtotal	\$0.00	\$0.00	\$0.00
TOTALS							\$146,100.00	\$146,100.00	\$0.00	\$146,100.00

Submitted: _____
 (Contractor)
 Recommended: 
 (Engineer)
 Approved: _____
 (Owner)

Original Amount of Contract:	\$146,100.00
Approved Change Orders	\$0.00
Total Amount of Contract:	\$146,100.00
Total Amount of Work Completed:	\$146,100.00
Less Amount Retained:	0%
Net Amount Due on Contract:	\$146,100.00
Less Amount Previously Invoiced	\$131,490.00
Balance Due This Estimate:	\$14,610.00



Hidalgo County Drainage District No. 1

902 North Doolittle Road Edinburg, Texas 78542 Office: (956) 292-7080 Fax: (956) 292-7089

Invoice Processing Checklist

Date Received: 4-14-15

Engineer/Firm Name: Foremost Paving Inc. / Guzman & Muñoz

Project Name/Number: West Main Drain Existing Weir Mod...

Invoice No.: Application # 2

Purchase Order No.: _____

Received By: Rosa Arce

Forwarded to: Joey Garcia

Total # of Pages Submitted: 42 pages (As submitted)

Attachments: CD: _____ USB: _____ Other: Plans N/A: _____

Additional Comments: (2) Invoices submitted together # of pages

includes both invoices (As submitted.)



FOREMOST PAVING, INC.

P.O. BOX 29 WESLACO, TEXAS 78599-0029

March 23, 2015

Mr. Jose Luis Muniz., P.E.
Guzman & Muñoz Engineering & Surveying Inc.
2020 E. Expressway 83.
Mercedes, Texas 78570

Re: HCDD #1 Pct No. 4 Area – West Main Drain Existing Weir Modification &
Existing Concrete Culvert Slide Gate Control Structure Improvements Monthly Estimate

Dear Mr. Muniz,

Enclosed is the March Estimate for the above-mentioned project.

Please process for payment at your earliest convenience.

If I can be of additional service, please feel free to contact me.

Sincerely,

A handwritten signature in black ink, appearing to read 'Juan Galvan'. The signature is stylized with loops and a long horizontal stroke at the end. Below the signature, the name 'Juan Galvan' is printed in a standard font.

Juan Galvan

APPLICATION AND CERTIFICATE FOR PAYMENT

TO OWNER:

Hidalgo County Drainage District No. 1
902 North Doolittle
Edinburg, Tx 78539

PROJECT:

HCDD #1 Pct #4 Area-West Main Drain
Existing Weir Modification &
Existing Concrete Culvert Slide
Gate Control Structure Imp

APPLICATION #: 2

APPLICATION DATE: 3/23/2015

PERIOD TO: 3/23/2015

PROJECT NO: HCDD1-14-003-02-05

P.O. NO.:

CONTRACT DATE: 2/11/2014

CONTRACT DAYS: 120

CONTRACT FIRST WORK DAY: 2/13/2015

Page 1 of 2 Pages

DISTRUBUTION TO:

X	Owner
	Const. Man.
	Architect
	Contractor
	Engineer

RECEIVED
HIDALGO COUNTY
DRAINAGE DISTRICT #1

FROM CONTRACTOR:

Foremost Paving, Inc.
P.O. Box 29
Welaco, Tx 78599

ENGINEER:

Guzman & Muñoz Engineering
2020 E. Expressway 83
Mercedes, Tx 78570

CONTRACT FOR: HCDD#1 Pct #4 Area - Project West Main Drain Existing Weir Modification & Existing Concrete Culvert Slide Gate Control Structure Improvements

APR 14 2015
9:51 AM / PM
BY: *Risa Orce*

CONTRACTOR'S APPLICATION FOR PAYMENT

Application is made for payment, as shown below, in connection with the contract. Continuation Sheet is Attached

1. Original Contract Sum -----	\$	146,100.00
2. Net Change by Change Orders -----	\$	-
3. Contract Sum to Date (Line 1+/- 2) -----	\$	146,100.00
4. Total Completed & Stored To Date -----	\$	146,100.00
A. Materials on Hand -----	\$	-
5. Retainage -----	\$	14,610.00
a. 10.0% of Completed Work -----	\$	-
b. 10% of Stored Material -----	\$	131,490.00
Total In Column O of Continuation Sheet -	\$	70,965.00
6. Total Earned Less Retainage -----	\$	60,525.00
7. Less Previous Certificates for Payment -----	\$	-
8. Current Balance Payment Due -----	\$	-
9. Balance to Finish, Including Retainage -----	\$	-

The undersigned Contractor certifies that to the best of the Contractor's knowledge, information and belief the work covered by this Application for Payment has been completed in accordance with the Contract Documents, that all amounts have been paid by the Contractor for work for which previous Certificates for Payment were issued and payments received from the Owner, and that current payment shown therein is now due

CONTRACTOR: Foremost Paving, lbc.

By: *[Signature]* Date: 3/23/15

State of Texas

County of Hidalgo

Subscribed and Sworn to me before this

Notary Public

My Commission Expires:

[Signature] March 19, 2018

CERTIFICATE FOR PAYMENT

In accordance with Contract Documents, based on on-site observations and the data comprising application, the Engineer certifies and the Owner certifies to the best of the Engineer's knowledge, information and belief the Work has progressed as indicated, the quality of the Work is in accordance with the Contract Documents, and the Contractor is entitled to payment of the AMOUNT CERTIFIED

AMOUNT CERTIFIED-----\$ 60,525.00

(Attach explanation if amount certified differs from the amount applied for. Initial all figures on this application and on the continuation sheet that are changed to conform to the amount certified)



CHANGE ORDER SUMMARY

owner	ADDITIONS	DEDUCTIONS
Total changes approved in previous months by owner	\$0.00	\$0.00
Total approved this month	\$0.00	\$0.00
Totals	\$0.00	\$0.00

Engineer: Guzman & Muñoz Engineering

By: *[Signature]*
Date: 3/23/15

This Certificate is not negotiable. The AMOUNT CERTIFIED is payable only to the Contractor name herein. Issuance, payment and acceptance of payment are without prejudice to any rights of the owner of contractor under this Contract

NET CHANGES by Change orders

CONTRACTOR'S AFFIDAVIT OF RELEASE OF LIENS

PROJECT: West Main Existing Weir Modification & Concrete Culvert

PROJECT NO. HCDD1-14-003-02-05

Slide Gate Control Structure Improvements

OWNER: Hidalgo County Drainage District No. 1

CONTRACTOR: Foremost Paving, Inc.

ENGINEER: Guzman & Munoz Engineering and Surveying, Inc.

The Contractor, in accordance with the Contract Documents, and in consideration for the full and final payment to the Contractor for all services in connection with the project, does hereby waive and release any and all liens, or any and all claims to liens which the Contractor may have on or affecting the project as a result of its contract(s) for the Project or for performing labor and/or furnishing materials in any way connected with the construction of any aspect of the project. The Contractor further certifies and warrants that all subcontractors of labor and/or materials for the Project, except as listed below, have been paid in full for all labor and/or materials supplied to, for through or at the direct or indirect request of the Contractor prior to, through and including the date of this affidavit.

EXCEPTIONS: (If none, write "NONE". The Contractor shall furnish a bond acceptable to the Owner for each exception.) NONE

CONTRACTOR

By

[Signature]

Title

President

Subscribed and sworn to before me this

31st March

day of

2015

Notary Public:

Martha Garza

My Commission Expires:

12-9-18

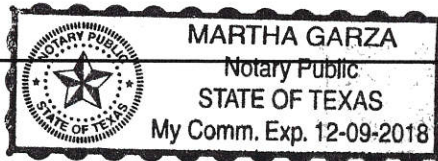

**CONTRACTOR'S AFFIDAVIT OF
PAYMENTS OF DEBTS AND CLAIMS**

PROJECT: West Main Existing Weir Modification & Concrete Culvert
Slide Gate Control Structure Improvements
OWNER: Hidalgo County Drainage District No. 1
CONTRACTOR: Foremost Paving, Inc.
ENGINEER: Guzman & Munoz Engineering and Surveying, Inc.

PROJECT NO. HCDD1-14-003-02-05

The Contactor in accordance with the Contract Documents, hereby certifies that, except as listed below, all obligations for all materials and equipment furnished, for all work labor, and services performed, and for all known indebtedness and claims against the Contractor for damages arising in any manner in connection with the performance of the Contract referenced above for which the Owner or his property might in any way be held responsible have been paid in full or have otherwise been satisfied in full.

EXCEPTIONS: (If none, write "NONE". The Contractor shall furnish a bond acceptable to the Owner for each exception.) NONE

CONTRACTOR

By

Title *President*

Subscribed and sworn to before me this

31st

day of

march 2015

Notary Public:

Martha Garza

My Commission Expires:

12-9-18

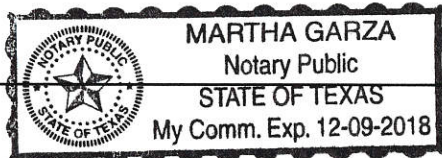

Unconditional Waiver and Release on Final Payment

Project: **HCDD1-14-003-02-11 West Main Drain Existing Weir Modifications & Concrete Slide Gate Control Improvements**

Job No.: **HCDD #1 DRAIN**

The signer of this document has been paid in full for all labor, services, equipment, or materials furnished to the property or to **Foremost Paving, Inc.** on the property of **Hidalgo County Drainage District 1** located at **McAllen, Texas** to the following extent: **Water and Wastewater Materials**. The signer therefore waives and releases any mechanic's lien right, any right arising from a payment bond that complies with a state or federal statute, any common law payment bond right, any claim for payment, and any rights under any similar ordinance, rule, or statute related to claim or payment rights for persons in the signer's position.

The signer warrants that the signer has already paid or will use the funds received from this final payment to promptly pay in full all of the signer's laborers, subcontractors, materialmen, and suppliers for all work, materials, equipment, or services provided for or to the above referenced project up to the date of this waiver and release.

Dated: 04/01/15

Company: **Aguaworks Pipe & Supply, LLC.**

Charles Scott Bennett

By: **Charles Scott Bennett**

Title: **Vice President**

State of Texas
County of Cameron

This Conditional Waiver and Release on Final Payment was acknowledged before me on this **1st** day of **April 2015**, by **Charles Scott Bennett**, on behalf of **Aguaworks Pipe & Supply, LLC** a **Limited Liability Corporation**.

Seal

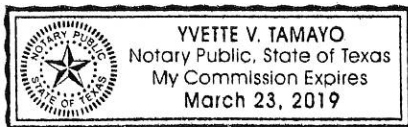

[Signature]
Notary Public State of Texas
My Commission Expires:

PARTIAL RELEASE OF LIEN AND CLAIM

THE STATE OF TEXAS §
§
COUNTY OF CAMERON §

In consideration of the sum of \$10, and other good and valuable consideration, the receipt and sufficiency of which is hereby acknowledged, **Aguaworks Pipe & Supply, LLC**, hereinafter referred to as "Claimant, does the following:

1. Claimant hereby acknowledges that it has received the sum of **\$54,391.88** in partial settlement and partial payment of the claims which claimant has against **Foremost Paving, Inc** as the result of furnishing materials and/or labor for the construction of improvements on the following described real property: **HCCD1-14-003-02-11 West Main Drain Existing Weir Modifications & Concrete Culvert Slide Gate Control Improvements.**
2. Claimant partially releases such party or parties to the extent, and only to the extent, of the payment received and shown above.
3. Claimant, for the Claimant and its successors and assigns, further partially releases that certain lien claimed against the above-described property and evidenced by an affidavit filed in the Real Property Records of Cameron County, Texas, to the extent and only to the extent of the following portion of the indebtedness paid: **\$54,391.88.**

Claimant hereby expressly reserves all causes of action and rights to recover all other sums of money due and owing to Claimant by the person or persons partially released hereby and Claimant expressly reserves any lien rights on the real property as claimed in that certain affidavit described above to the full extent of the claim stated therein, less the indebtedness credited in paragraph 3 above.

Executed on this 30 day of March 2015.

Aguaworks Pipe & Supply, LLC.

By: Thomas H. Bennett Jr.
Thomas H. Bennett Jr., President

STATE OF TEXAS
COUNTY OF CAMERON

This release of lien was acknowledged before me on the 30 day of March, 2015 by **Thomas H. Bennett Jr.**, on behalf of **Aguaworks Pipe & Supply, LLC.**

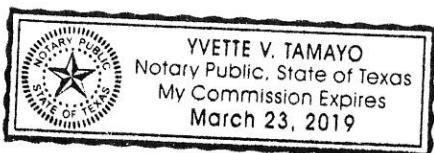

[Signature]
Notary Public, State of Texas

HIDALGO COUNTY DRAINAGE DISTRICT NUMBER ONE

902 NORTH DOOLITTLE

EDINBURG, TEXAS 78542

(956) 292-7080

FAX (956) 292-7089

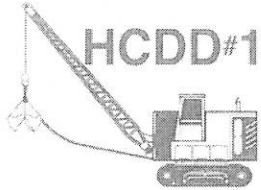

LETTER OF TRANSMITTAL

GODFREY GARZA, JR., CFM
DISTRICT MANAGER
FLOODPLAIN ADMINISTRATOR

902 N. Doolittle
Edinburg, TX 78542
956-292-7080
956-292-7089-FAX

Date: 07.28.2014

TO: Foremost Paving
SUZMAN & MUNOZ

FROM: J. SALAZAR

ATTENTION: Jos Munoz

JOB TITLE: _____

REASON FOR TRANSMITTAL CHECKED BELOW:

- | | | |
|---|--|--|
| <input type="checkbox"/> AS REQUESTED | <input type="checkbox"/> FOR APPROVAL | <input type="checkbox"/> REVIEW AND COMMENT |
| <input type="checkbox"/> RETURNED FOR CORRECTIONS | <input type="checkbox"/> APPROVED AS NOTED | <input type="checkbox"/> OTHER |
| <input type="checkbox"/> APPROVED AS SUBMITTED | <input type="checkbox"/> COPY OF LETTER | <input checked="" type="checkbox"/> HAND DELIVERED |

REMARKS: Submitted WMD for most paving

Received by: [Signature]

5/7/2014: FPI MEASUREMENTS OF EXISTING 10'X10' BOX CULVERTS

P 790-06
 3 WEST Main Drain
 Control

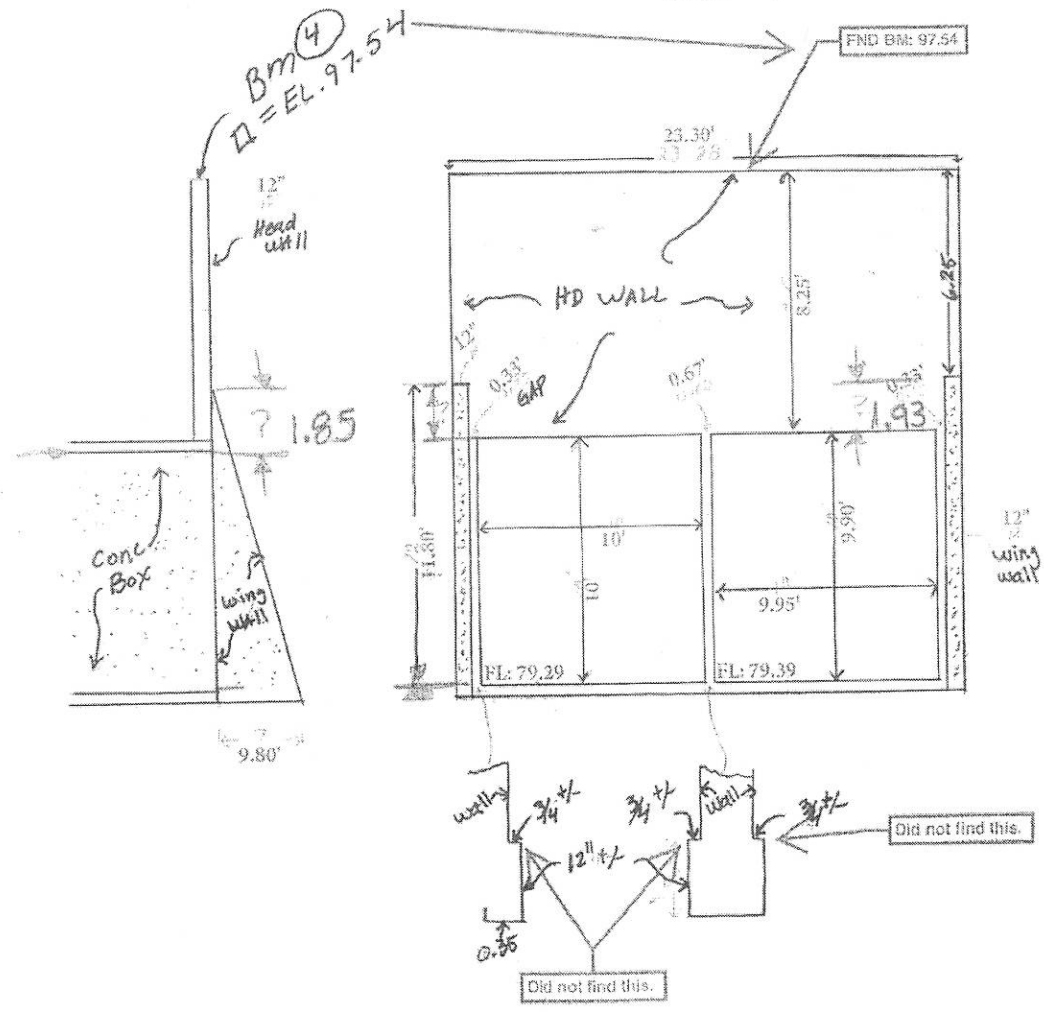

LOOKING EAST

DATE CHECKED	CHECKED BY	COMPILED BY	DATE	CAD/TA	SCALE
PROJECT			SUBJECT		

FOREMOST PAVING, INC.
 P.O. BOX 3244
 MCALLEN, TX 78502
 Ph: 956-686-7819
 Fax: 956-686-7824

Letter of Transmittal

To: GUZMAN AND MUNOZ ENGINEERING
 2020 East Expressway 83
 Mercedes, TX 78570
 (956) 565-4637; Fax: (956) 565-4636

Transmittal #: 001
 Date: 7/14/2014
 Job: 14-616 HCDD #1 W. Main Drain Weir Mod

Subject: Submittal - 001 (Sluice Gate)

- WE ARE SENDING YOU Attached Under separate cover via the following items:
- Shop drawings Prints Plans Samples
- Copy of letter Change order Specifications Submittal

Document Type	Copies	Date	No.	Description
Submittal	1	7/14/14	11285-001 Rev 0	Submittal - 001 (Sluice Gate)

THESE ARE TRANSMITTED as checked below:

- For approval Approved as submitted Resubmit ___ copies for approval
- For your use Approved as noted Submit ___ copies for distribution
- As requested Returned for corrections Via Fax 0 Pages, Including Cover
- For review and comment Other
- FOR BIDS DUE PRINTS RETURNED AFTER LOAN TO US

Remarks: A copy of the submittal for the sluice gate is attached for review and approval.

Copy To:

From: Jimmie R. McPherson (Foremost)

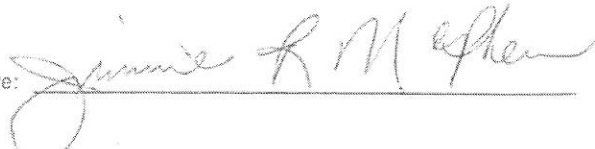
Signature: 

FOREMOST PAVING, INC.
P.O. BOX 3244
MCALLEN, TX 78502
Ph: 956-686-7819

Submittal

Job: 14-616
HCDD #1 W. Main Drain Weir Mod

Spec Section No: 11285
Submittal No: 001
Revision No: 0
Sent Date: 7/14/2014

Spec Section Title:
Submittal Title:

Contractor:
FOREMOST PAVING, INC.

Contractor's Stamp
FOREMOST PAVING, INC.

APPROVED APPROVED AS NOTED
 REVISE & RESUBMIT REJECTED

Reviewed as it relates to general compliance with the Contract Documents. Approval does not relieve Subcontractor/Vendor of the responsibility for Adequacy of design, correctness of dimensions, coordination of work with other trades and accuracy of detail.

By: Guillermo R. Alfaro Date: 07/14/2014

GUZMAN AND MUNOZ ENGINEERING

Engineer's Stamp
GUZMAN & MUÑOZ ENGINEERING AND SURVEYING, INC

Submittal review indicates general compliance or acceptability; however, it does not relieve the Contractor of final responsibility for proper dimensions, character, quantity, quality, strength or sufficiency of the items submitted. Any deviations not clearly identified, as deviations have not been reviewed. Information not submitted has not been reviewed.

Approved Revise and resubmit
 Rejected Rejected

Reviewed by: [Signature] Date: 7-22-2014

WINGWALL ON RIGHT IS SET FURTHER OUT THAN INSIDE OF BOX. SITE NEEDS TO ACCOUNT FOR THIS DIFFERENCE.



Fontaine

Formal approval of these drawings is required
before manufacturing can proceed.

SUBMITTAL DOCUMENT

Project Name : WEST MAIN DRAIN CONTROL

Purchasing customer : AGUAWORKS PIPE & SUPPLY, LLC

P.O. Number : 1009526

Contract No. : 5131453

Submittal No. : 5131453 - S1

DATE :	07/11/2014
DESCRIPTION :	Stainless Steel Gate

MANDATORY APPROVAL STAMP :

--

IMPORTANT MESSAGE TO CONTRACTOR :

The contractor who will be installing equipment supplied by Fontaine is responsible for ensuring that all dimensions shown herein are compatible with adjacent equipment and/or structures supplied by others. Fontaine will not be held responsible in case of dimensional incompatibility with the installation environment.

TABLE OF CONTENTS - SUBMITTAL NO. S1

ITEM	QTY	MODEL	IDENTIFICATION	PAGE	REVISION
ITEM 01	1.0	MODEL: 203 - 120" X 120" - B - CW/EC		3	0
ITEM 02	1.0	PORTABLE OPERATOR: SERIES (25 PO) with 10 feet of...		5	0

ANNEX	DESCRIPTION	PAGE	REVISION
1	Comments	7	0
2	Series 20 - Stainless Steel Sluice Gate - Installation, Operation and Maintenance Manual	8	0
3	Model 25 Portable Operator - Operation and Maintenance Manual	25	0

**FOR INFORMATION CONCERNING THIS SUBMITTAL,
PLEASE CONTACT YOUR PROJECT MANAGER :**

Project Manager : Omar Torres Email : O.Torres@vag-group.com Phone : +1-978-673-5205
--

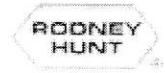

RHC Shop Order #: 5131453
Customer: AGUAWORKS PIPE & SUPPLY, LLC
Project Engineer: GWS

Date: July 11, 2014
Transmittal 1

GENERAL COMMENTS

1. Rodney Hunt has interpreted the dimensions of the structure to the best of our ability. The dimensions, quantities and type of equipment should be verified. Any submitted elevations or dimensions not verified or corrected will be assumed correct. Manufacture of equipment will be based on the elevations and dimensions submitted unless otherwise noted by the consultant or contractor in writing as a part of the approval process.
2. The manufacture of equipment will be based on the frame types submitted unless otherwise noted by the consultant or contractor in writing as a part of the approval process.
3. Spare Parts List: No special tools are provided or required for this equipment. Standard tools commonly used by Millwrights, Electricians, and Maintenance Mechanics are sufficient for installation, start-up and maintenance of Rodney Hunt equipment. The equipment is designed for a very long service life, therefore, we do not recommend stocking of any spare parts by the owner. In the event that replacement parts or seals are necessary, please refer to operation and maintenance manual for instructions.
4. Please note that we are providing a copy of the Operation & Maintenance Instruction Manuals. These manuals contain complete safety, storage, handling, installation, operation, maintenance, and repair information for the supplied equipment. Please note that Rodney Hunt Company suggests that O&M manuals be made available to site operation and maintenance personnel for their use.

INSTALLATION & MAINTENANCE MANUAL

SERIES 20

STAINLESS STEEL FLOW CONTROL SLUICE GATES

TABLE OF CONTENTS

Introduction	2
Receiving and Storage	2
Installation on a Concrete Wall	3
Installation on a Wall Thimble	6
Installation on a Standard Flange	9
Installation on a Round Manhole	9
Installation of a Gate Operator, Stem and Guide	10
Stop-Nut Installation and Adjustment	11
Troubleshooting	12
Adjustments	13
Inspection and Maintenance	13
Procedure for Seal Replacement	14
Lubricants	15
Spare Parts	15
Limited Warranty	16

INTRODUCTION

The purpose of this manual is to provide the contractor with information required to properly install Fontaine gates. Carefully read all instructions prior to starting installation, and contact Fontaine if you have any questions.

RECEIVING AND STORAGE

Although caution has been taken during assembling, crating and loading, damages may have been caused during transportation or storage. We recommend the following procedure when you receive the material:

Visually check for possible damage caused during transportation. Also, note the condition of the packing. If there are any signs of damage such as: a broken skid or box, or warped parts or tubes, these are signs that the shipment may have been improperly handled and that more serious damage may have occurred.

NOTE ANY DAMAGE TO EQUIPMENT OR CRATING ON THE WAYBILL OTHERWISE YOUR CLAIM WILL NOT BE ACCEPTED.

- 1) Check the packing list to make sure all the equipment has been received (stem, stem guide, gearbox, gates, etc.). Also, verify all the equipment numbers. This should be done within three days of delivery.

No claim for missing parts will be accepted afterwards

- 2) Cover and protect all equipment that is not to be installed immediately:
 - Leave gates strapped to skid.
 - Cover with tarp.
 - Store on an even surface in a clean, dry area.
 - Do not stack the gates.
 - Support stem evenly and keep off the ground.
 - Put all remaining parts in a secure area.

INSTALLATION ON A CONCRETE WALL

- 1) Never disassemble the gate without the manufacturer's authorization.
- 2) The wall should be even (see figure 2) and smooth. All imperfections should be removed by grinding or filled with epoxy grout.
- 3) Check for gate warping. Make sure the upper slide rails are parallel as shown in figure 1. Length A should be equal or up to 3mm (1/8") longer than B.
- 4) Thoroughly clean the back of the gate and the wall surrounding the opening with paint cleaner.
- 5) Glue the seal on the gate with contact cement.
- 6) Line up the gate on the opening. On each side of the gate, drill and install an anchoring stud. When the alignment is perfect, drill and install the remaining anchoring studs. See figure 4 for the most common anchoring methods.
- 7) Partially tighten the four corner nuts on the cover part of the slide. The upper part should not touch the wall. If it does, the wall is uneven and must be ground (see figure 2).

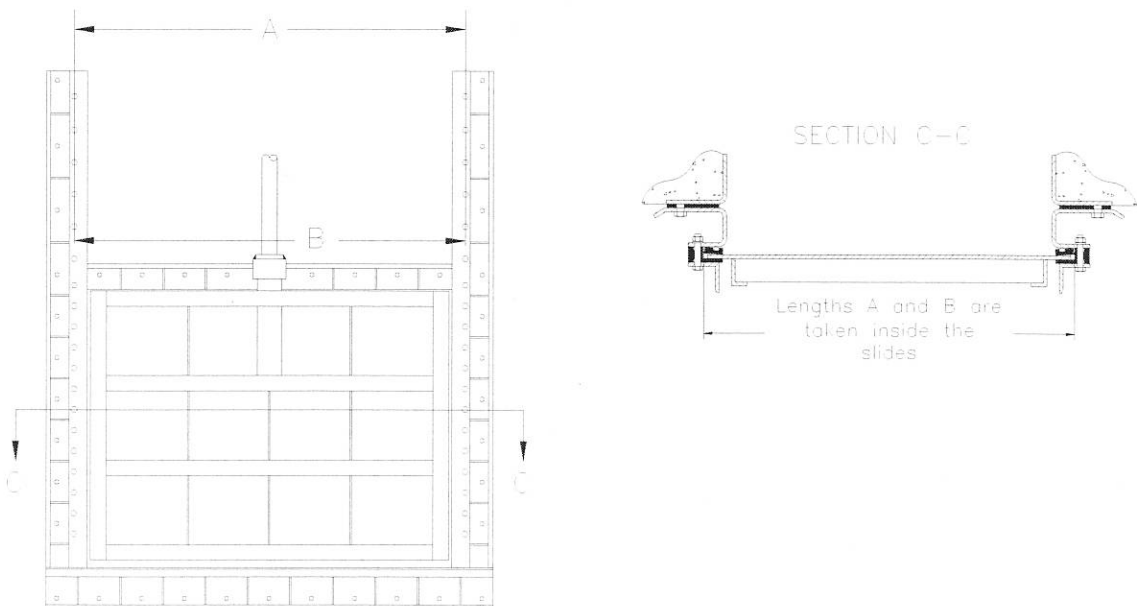

FIGURE 1

INSTALLATION & MAINTENANCE MANUAL STAINLESS STEEL GATES

- 8) Evenly tighten the nuts around the opening. Do not tighten nuts on the upper part of the slide immediately. Table 1 gives the torque values for standard fasteners. Figure 3 shows the tightening pattern. Apply equal torque to all nuts. Before completely tightening all the nuts, ensure the upper part of the slide is not touching the wall.

CAUTION: Over tightening of the cross-frame can affect the gates sealing capacity.

- 9) The upper part of the slides over the opening must also be anchored to the concrete wall. If the wall is even and smooth, use the resilient shims at each anchor's position (see figure 3a). If it is uneven, you must shim the slides with appropriate stainless steel washers to ensure vertical alignment.
- 10) If the gate is installed with a flush bottom frame (see figure 5), you should conduct a sealing test before pouring the grout. If the gate has a frame embedded section, make sure the frame is square and level before pouring the grout.

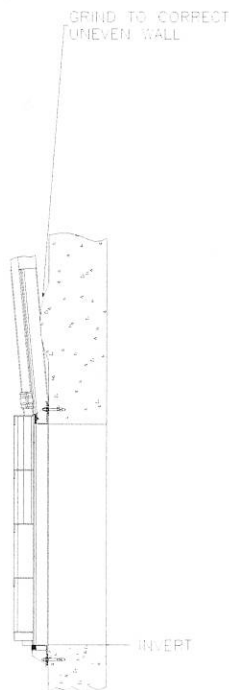

FIGURE 2

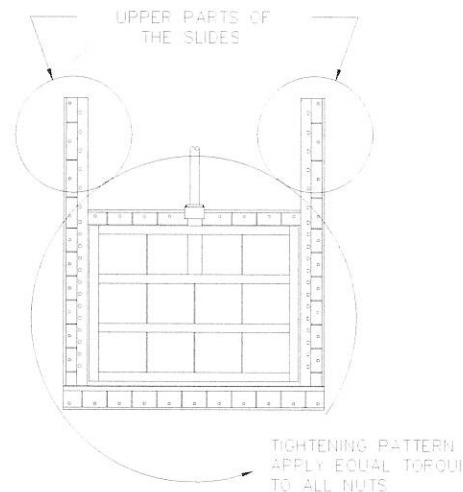

FIGURE 3

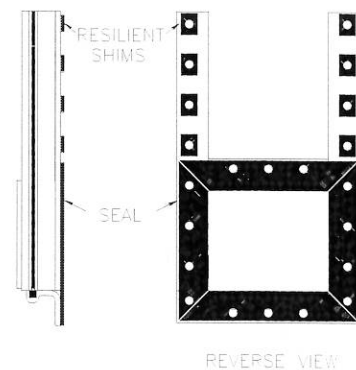

FIGURE 3a

INSTALLATION & MAINTENANCE MANUAL STAINLESS STEEL GATES

- 11) It is very important to thoroughly clean the UHMWPE slides, upper and bottom seals, in order to eliminate any metal or concrete residues. You should clean around the gate to remove all residues that could be harmful to gate operation.
- 12) Install operator components (see section "Installation of Operator Components").

TABLE 1

STUD DIAMETER		TORQUE	
In	(mm)	ft-lb	(N-m)
1 / 2	12	35	47
5 / 8	16	75	102
3 / 4	20	100	136
7 / 8	22	150	203
1	25	200	271

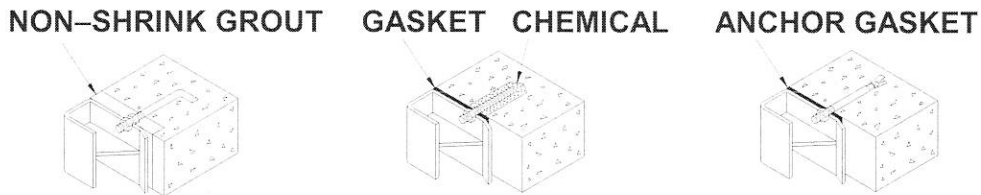

FIGURE 4

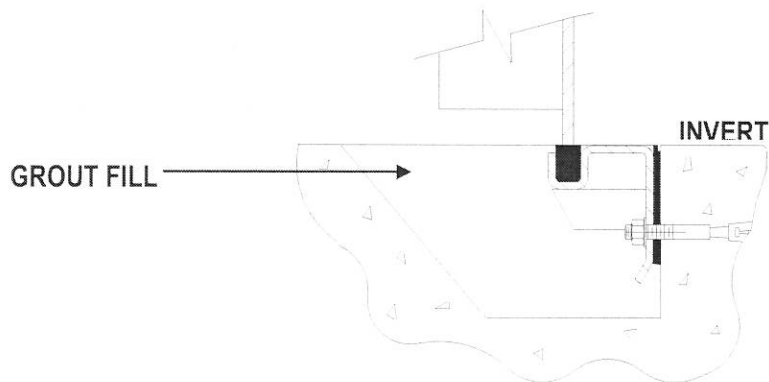

FIGURE 5

SURFACE CHECK FOR A CONCRETE WALL

Check the surface with a straight edge. The maximum permissible surface unevenness is 3 mm (1/8").

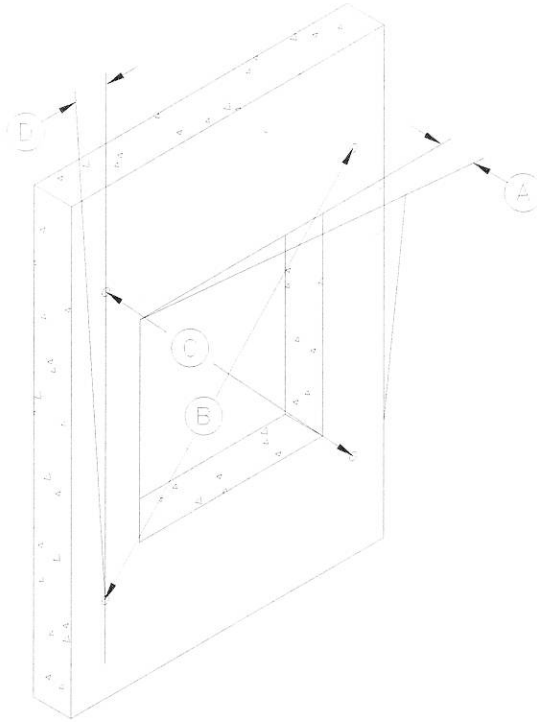

FIGURE 6

ACCEPTABLE TOLERANCES

- A Maximum allowable warping of 3mm (1/8") along the total length of each side.
- B – C Comparison of diagonals - Maximum difference of 3mm (1/8").
- D Maximum vertical alignment of 3mm (1/8") on the total length of side.

INSTALLATION ON A WALL THIMBLE

- 1) Never disassemble the gate without manufacturer authorization.
- 2) The wall thimble should be even (see [figure 5](#)). The concrete around the wall thimble should be even and have a smooth surface.
- 3) Check for gate warping. Make sure the upper slide rails are parallel as shown in [figure 1](#). Length A should be equal or up to 3 mm (1/8") longer than B.
- 4) Thoroughly clean the back of the gate and the wall surrounding the opening with paint cleaner.
- 5) Glue the seal on the gate with contact cement.
- 6) Line up the gate on the opening. Install anchoring studs on each side of the gate. When the alignment is perfect, screw the remaining anchoring studs in the wall thimble.
- 7) Partially tighten the four (4) corner nuts.
- 8) Evenly tighten the nuts on the sides, upper and lower parts of the gate according to the torque in [Table 1](#). Proceed according to the tightening pattern (see figure 1) until an even torque is obtained.
- 9) If the gate is installed with a flush bottom frame (see [figure 5](#)), you should conduct a sealing test before pouring the grout.
- 10) **It is very important to thoroughly clean** the UHMWPE slides, upper and bottom seals, and the gate in order to eliminate any metal or concrete residues. Make sure the gate surrounding is well cleaned and that there are no residues (wooden boards metal stems, etc.), which could be harmful to the gate operation.
- 11) Install operator components (see "Installation of the gate operator stem and guide").

SURFACE CHECK FOR A WALL THIMBLE

Check the surface with a straight edge. The maximum permissible surface unevenness is 3 mm (1/8").

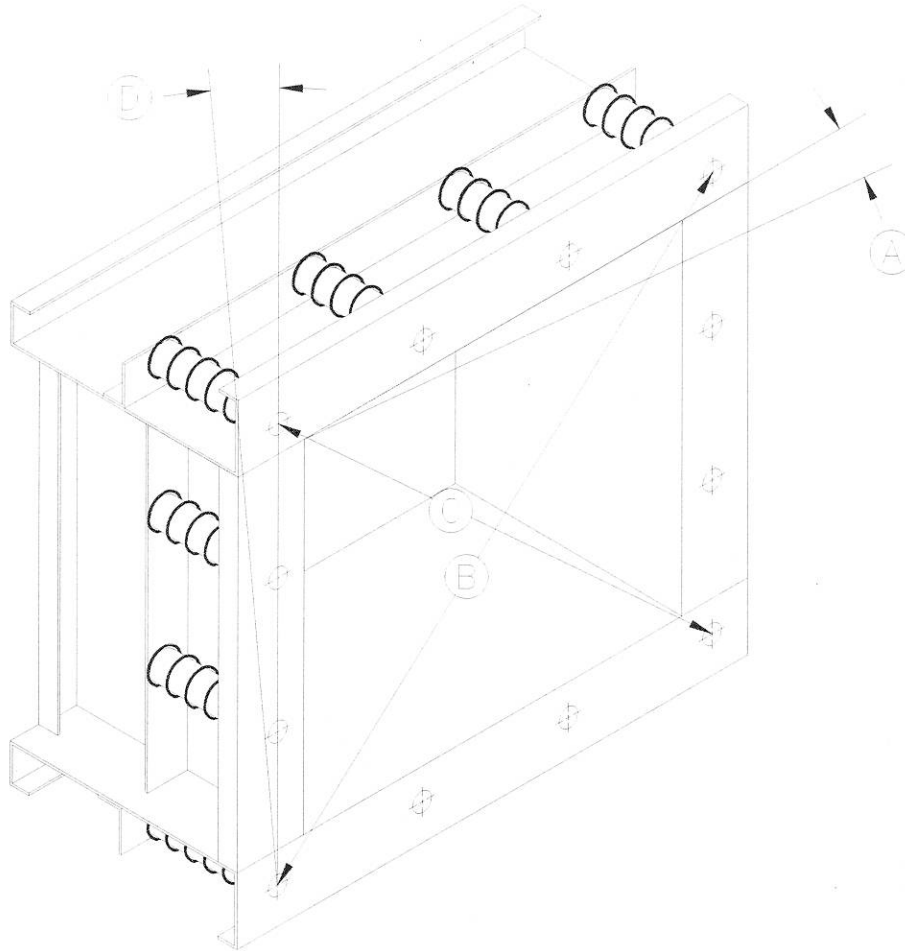

FIGURE 8

ACCEPTABLE TOLERANCES

- A Maximum allowable warping is 3mm (1/8") along the total length of each side.
- B - C Maximum difference between diagonals is 3mm (1/8").
- D Maximum vertical alignment is 3mm (1/8") along the length of each side.

INSTALLATION ON A STANDARD FLANGE

- 1) Never disassemble the gate without manufacturer authorization.
- 2) The flange should be even and smooth. All imperfections should be corrected before work is continued.
- 3) Check for gate warping. Make sure the upper slide rails are parallel as shown in figure 1. Length A should be equal or up to 3 mm (1/8") longer than B.
- 4) Thoroughly clean the back of the gate and the wall surrounding the opening with paint cleaner.
- 5) Glue the seal on the gate with contact cement.
- 6) Line up the gate on the opening. Install the anchoring bolts and nuts.
- 7) Evenly tighten the nuts around the flange. Table 1 gives the torque values for standard fasteners. Figure 3 shows the tightening pattern. Apply equal torque to all nuts.
- 8) It is very important to thoroughly clean the UHMWPE slides, upper and bottom seals, and gate in order to eliminate any metal or concrete residues. You should clean around the gate to remove all residues which could be harmful to gate operation.
- 9) Install operator components (see the relevant section).

INSTALLATION ON A ROUND MANHOLE

Follow the instructions under "Installation on a concrete wall". Be sure that anchoring studs will allow gate removal after installation if needed.

INSTALLATION OF A GATE OPERATOR, STEM AND GUIDE

Note: If the gate, yoke and operator stem are already assembled together, only steps 5, 7, and 8 apply.

- 1) Place and align the components in position as indicated in figure 9.
- 2) Install the extension tube or shaft to the top of slide or gate.
- 3) Insert the stem guide brackets (figure 9). Make sure to install them at the right location (see approval drawings).
- 4) Install the extension tube, if required, with bolts or with couplings if applicable.
- 5) Thoroughly clean the threaded part of the stem and the nut in the lifting device. Keep these elements clean and lubricated to prevent damage and hard operating.
- 6) Engage the stem in the lift nut with care to avoid damaging the thread. Hold stem and turn the operator to bring it to the desired position.
- 7) ***It is very important to*** carefully check the alignment of the lifting components. The maximum allowable deviation for misaligned stems is 3mm (1/8") on the length of the stem (see figure 9). Use anchor studs to fasten the stem guides in position. Shim with stainless-steel washers or plates if the wall is uneven.
- 8) Clean the gate and lifting mechanism thoroughly.

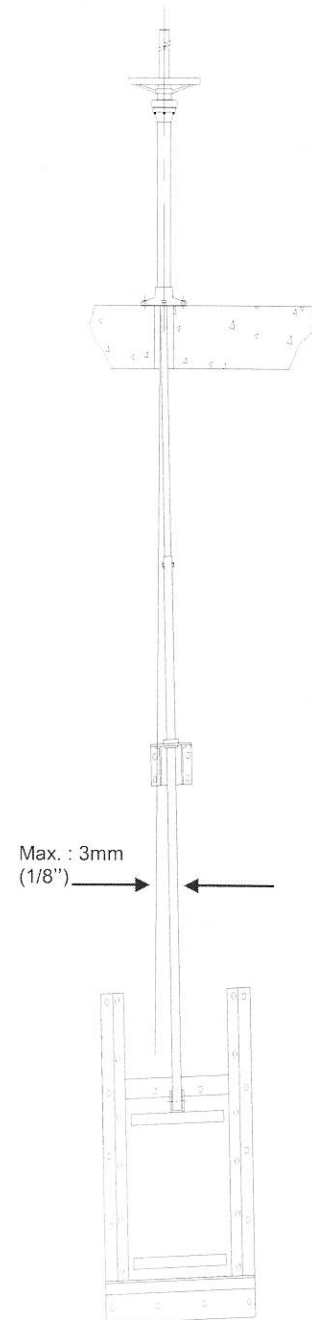
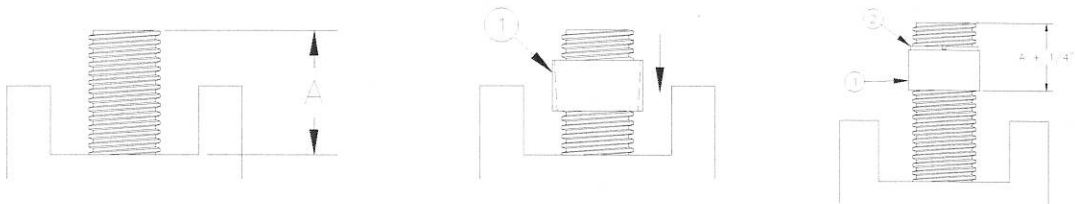

FIGURE 9

STOP NUT INSTALLATION & ADJUSTMENT

Note: The stop nut must be installed according to the following instructions in order to prevent damage to major components of the gate.

1. Lower the gate to its fully closed position.
2. Measure the distance between the stem's extremity and the top of the actuator's lift-nut (A).



3. Open the gate approximately 12 inches (30 cm).
4. Insert the tapered ring ① on the stem (the thickest section should be on the actuator side).
5. Screw the threaded ring ② on the stem and raise the tapered ring ① until both rings are positioned together. The bottom of the tapered ring ① should be at a distance (A) + 6mm (1/4") from the bottom of the actuator.
6. When accurately positioned, lock in place by carefully hitting the tapered ring ① upward in order to secure against the threaded ring ②.

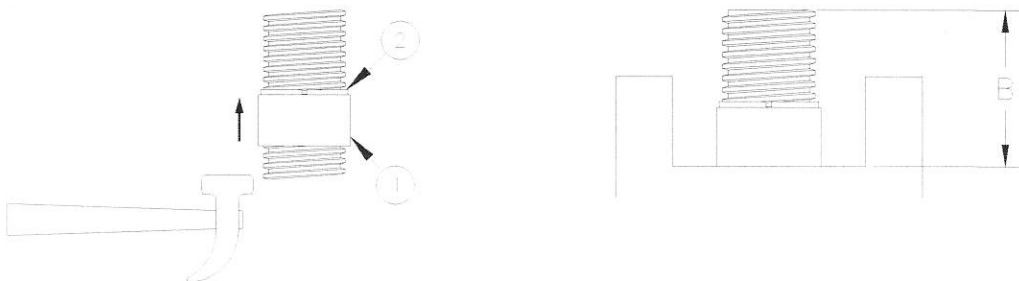

7. Lower the gate to its fully closed position and measure the distance between the stem's extremity and the top of the actuator's lift-nut (B).

If distance (B) is not the same as (A), correct the position of the treaded ring ② until (A) and (B) are equal.

TROUBLESHOOTING

NEVER FORCE THE OPERATOR TO CLOSE THE GATE, SINCE PERMANENT SEAL DAMAGE MAY OCCUR.

<u>SYMPTOM</u>	<u>CAUSE</u>	<u>REMEDY</u>
LEAKAGE	Wood, concrete, or other foreign matter on seat facing.	Carefully remove the foreign matter. Check for permanent seal damage.
	Loose anchoring studs.	Tighten loose nuts according to table 1.
	Excessive tightening of cross-frame.	Partially loosen cross-frame anchoring nuts.
EXCESSIVE FORCE REQUIRED TO OPERATE	Misaligned stem, stem guide, and hoist.	Realign stem, stem guide, and hoist. Check and adjust the alignment.
	Improperly installed or warped frame.	Check frame for warping. Consult the manufacturer if warping is found.
	Nut and stem dirty or dry.	Clean and lubricate threads.

For problems that cannot be solved with the troubleshooting procedure, call Rodney Hunt – Fontaine, Inc. at (978) 544-2511, and ask for the Field Service Department. If a leak is involved, try to locate it before calling.

ADJUSTMENTS

Series 20 sluice gates are shop-adjusted and tested, so they should normally require no adjustment after installation.

INSPECTION AND MAINTENANCE

To obtain maximum performance, Rodney Hunt – Fontaine, Inc. recommends the following procedures:

INSPECTION INTERVALS

- 1) Initial inspection after 25 operating cycles or 2 weeks of operation, whichever occurs first.
- 2) Second inspection after 50 operating cycles after the first inspection or six months after operating, whichever occurs first.
- 3) Subsequent inspections every 100 operating cycles or six months, whichever occurs first.

Gates subjected to heavy-duty use should be inspected every 3 months.

A gate cycle means opening, then closing the gate.

THE FOLLOWING OPERATIONS SHOULD BE DONE AT EACH INSPECTION:

. GATE MAINTENANCE

- 1) Clean the gate with clear water to remove all deposits
- 2) Inspect the resilient seals and slides to make sure they are in good condition.

. STEM MAINTENANCE

- 1) Inspect stem threads and lift-nut threads for wear.
- 2) Clean and lubricate the stem.
- 3) All the fasteners should be checked for correct tightening.

PROCEDURE FOR SEAL REPLACEMENT

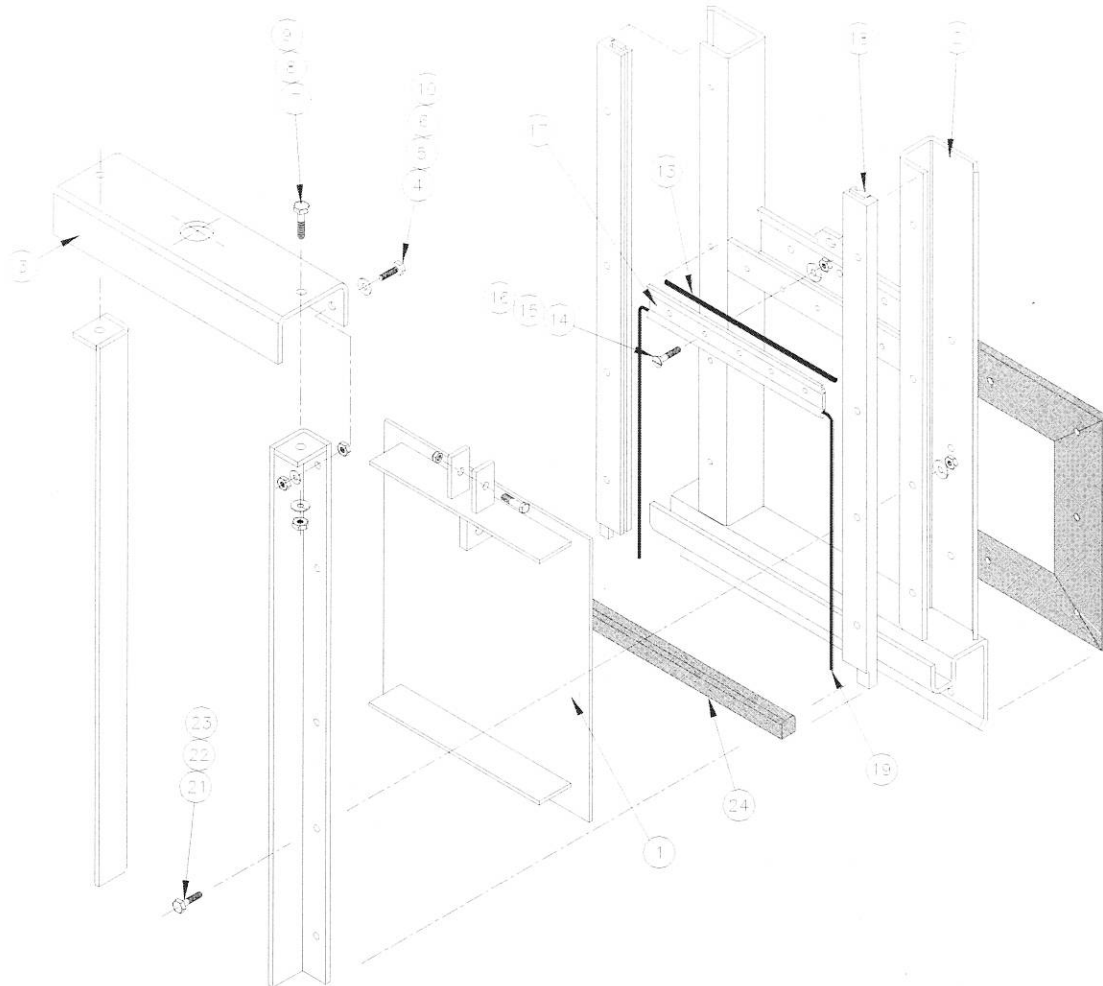

- 1) Remove items 4, 5, 6, 10 and 7, 8, 9 then remove yoke (3) [if equipped].
- 2) Lift the slide (item 1) out of the frame (2).
- 3) Remove items 21, 22, 23 and items 14, 15, 16 (retainer bolt).
- 4) Remove the UHMW seal retainer.
- 5) Remove items 18 (guide), 17 (upper seal) [if equipped], 24 (bottom seal) [if equipped], 13 and 19 (compression cord) and clean gate.
- 6) Install the bottom seal (item 24) [if equipped] using a 5 mm slalom cord of the Sikaflex glue in the frame channel.
- 7) Drill new UHMW seals using old seals as guides and install on gate.
- 8) For reassembly, do the steps 4 to 1.

The Sikaflex glue included, should be applied on all mating joints.

LUBRICANTS

The operating stem should always be well lubricated to ensure proper gate operation. Use one of the following lubricants:

- Esso "Unirex EP2"
- Shell "Gadus S2 V220-2"
- Texaco "Summit EPM2"
- Rocol "Tuflube Allweather" (European)
- Hydra Lube "TW 2 compound" (European)

In heavy duty application as modulating operation or frequently submerge threaded stem, use one of the following lubricants:

- Shell "SRS 2000"
- Petro-Canada "OG-2"
- Prolab "OG 700"
- Rocol "Tuflube Allweather" (European)
- Hydra Lube "TW 2 compound" (European)

If the gate is used in drinking water, use:

- Rocol "Sapphire Aqua-sil Hi-load" (European)

For food grade and non-toxic applications, use:

- Rocol "Foodlube multi paste" (European)
- Exxon "Foodrex FG 1"
- Shell "FM 2"
- Mineral oil

An equivalent is acceptable, according to condition of use's (contact your local Fontaine country office for further details and advice).

SPARE PARTS

Rodney Hunt – Fontaine, Inc. does not recommend that customers stock replacement parts, since the equipment has an excellent durability when properly maintained.

If a replacement part is necessary, contact our field service department with the following information:

- Gate serial number
- Part description
- Description of damages and causes
- Approximate delivery requirements

This information will enable us to serve you in a quicker and better manner.

LIMITED WARRANTY

Rodney Hunt – Fontaine, Inc. warrants that the Equipment manufactured by it and delivered hereunder will be free of defects in material and workmanship for a period of twelve months from the date of placing the Equipment in operation or eighteen months from the date of shipment, whichever shall first occur. The Purchaser shall be obligated to promptly report any failure to conform to this warranty, in writing to *Rodney Hunt - Fontaine, Inc.* within said period, whereupon *Rodney Hunt - Fontaine, Inc.* shall, at its option correct such nonconformity, by suitable repair to such Equipment or, furnish a replacement part F.O.B. point of shipment, provided the Purchaser has stored, installed, maintained and operated such Equipment in accordance with good industry practices and has complied with specific recommendations of *Rodney Hunt - Fontaine, Inc.* Accessories or equipment furnished by *Rodney Hunt - Fontaine, Inc.*, but manufactured by others, shall carry whatever warranty the manufacturers have conveyed to *Rodney Hunt - Fontaine, Inc.* and which can be passed on to the Purchaser. *Rodney Hunt - Fontaine, Inc.* shall not be liable for any repairs, replacements, or adjustments to the Equipment or any costs of labor performed by the Purchaser or others without *Rodney Hunt - Fontaine, Inc.* prior written approval. The effects of corrosion, erosion and normal wear and tear are specifically excluded. Performance warranties are limited to those specifically stated within *Rodney Hunt - Fontaine, Inc.* proposal.

Correction by *Rodney Hunt - Fontaine, Inc.* of nonconformity's whether patent or latent, in the manner and for the period of time provided above, shall constitute fulfillment of all liabilities of *Rodney Hunt - Fontaine, Inc.* for such nonconformity's, whether based on contract, warranty, negligence, indemnity, strict liability or otherwise with respect to or arising out of such Equipment. The Purchaser shall not operate Equipment which is considered to be defective, without first obtaining *Rodney Hunt - Fontaine, Inc.* written consent to do so. Any such use of Equipment will be at the Purchaser's sole risk and liability.

MODEL 25. PORTABLE OPERATOR



RODNEY HUNT CO.
ORANGE, MA 01364
TEL: 508-544-2511
FAX: 508-544-7204

- ◆ Easily Carried
- ◆ Eliminates Manual Operation
- ◆ Hydraulic Drive

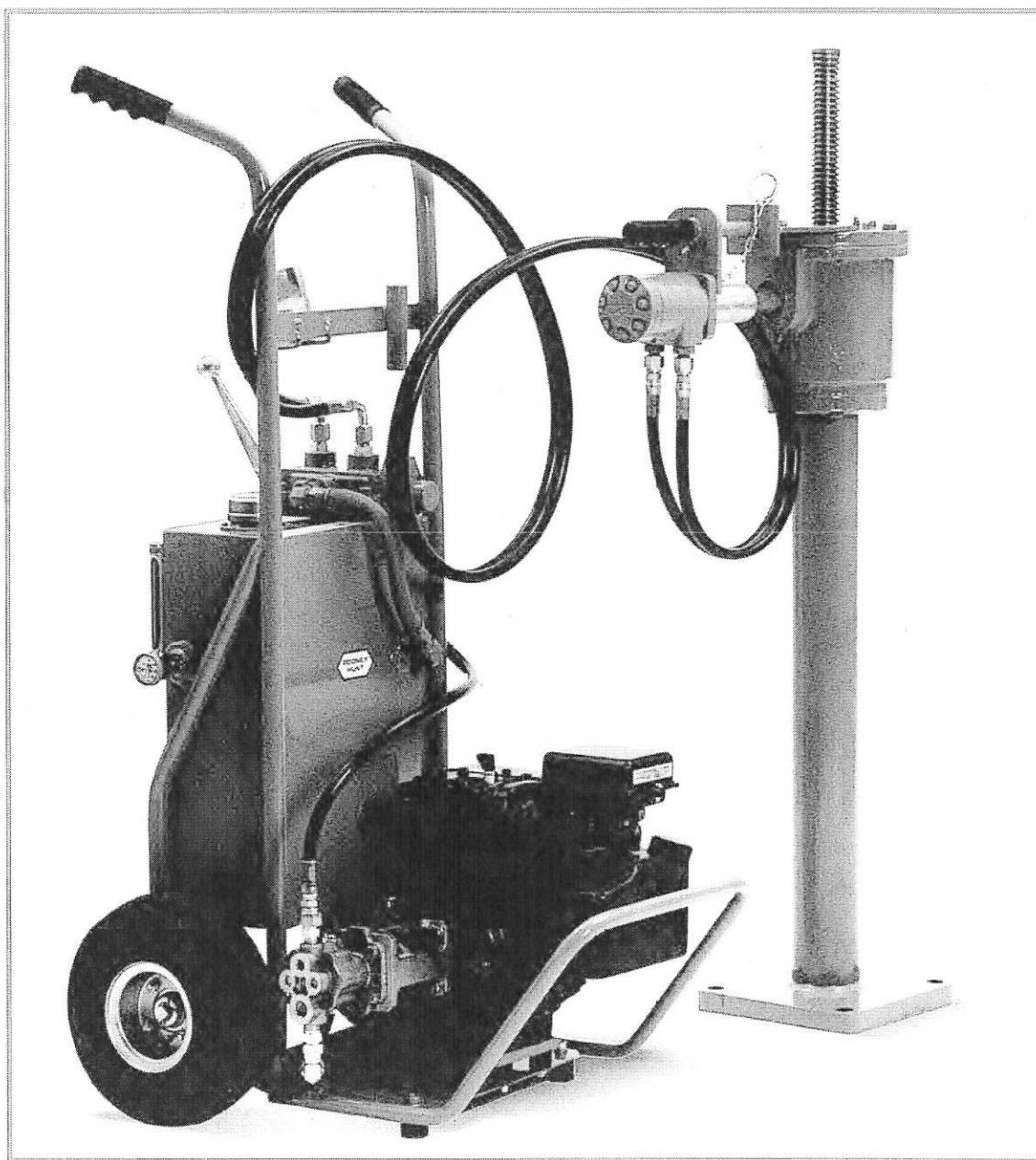

MODEL 25 PORTABLE OPERATOR



Rodney Hunt's Model 25 Portable Operator, a highly transportable unit with a gasoline-driven engine, utilizes a hydraulic pump and motor for the hoist drive. The motor is easily and quickly attached to a bracket permanently mounted on the hoist. The bracket absorbs all of the torque of operation. Flexible hydraulic hoses connect the motor to the controls at the portable operator.

A manual four-way valve starts, stops and reverses the rotation of the motor. An adjustable pressure relief valve built into the system limits the output torque of the unit.

The engine is a four-cycle, air-cooled unit with recoil rope starter and speed governor. The engine and hydraulic fluid reservoir are located low on the unit to increase its stability.

The pneumatic tires allow one man to easily move the unit on level ground. Handles at the lower end of the unit allow two men to carry the unit over rough ground and up stairs. The complete weight of the unit is approximately 160 lbs.

The Model 25 is designed to be used at installations with manual hoists, or as backup for an electric hoist. It can be provided with an electric motor drive for those applications where gasoline engine drive is not suitable.

SPECIFICATIONS

Hydraulic Motor: Gear type motor with easy to use, torque-resisting coupling rod.

Engine: 5 horsepower, 4 cycle, air-cooled engine. Gasoline powered. Recoil rope starter and speed governor. Higher horsepower available for special applications.

Pump: Positive displacement gear pump.

Control Valve: 3-position, detented valve with adjustable pressure relief, factory set to stop motor at 55 foot lbs. of torque.

Frame: Welded tubular frame with 5 gallon tank and filter mounted on two pneumatic tires. Fluid level and temperature gauges provided.

Weight: Complete unit weighs 160 lbs.



Water Control Equipment Division
RODNEY HUNT COMPANY
ORANGE, MA 01364
TEL: 508-544-2511
FAX: 508-544-7204

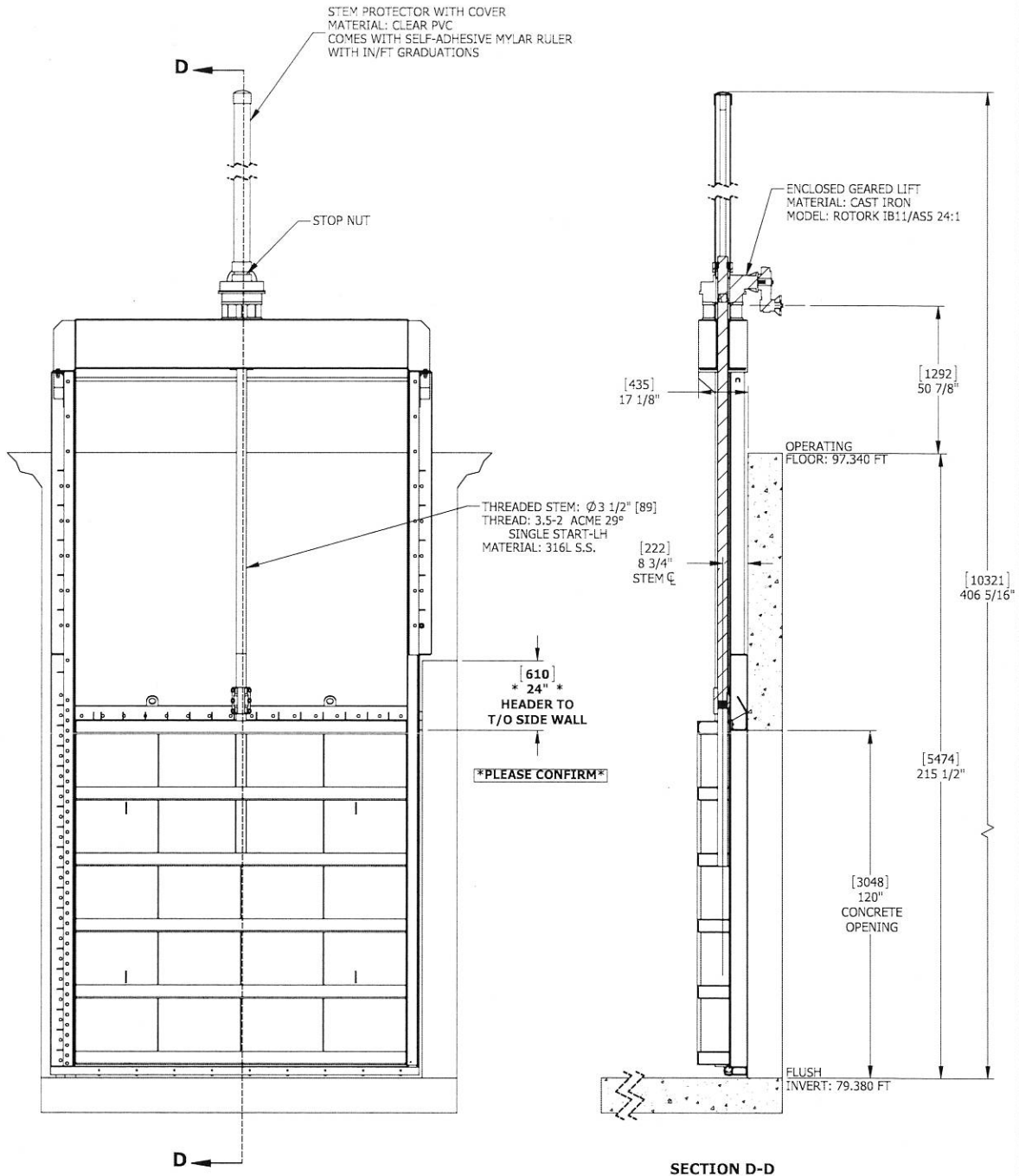

HEAD PRESSURE : 20	DRAWING BY: GARIN SUTTON	DATE: 7/11/2014	MODEL: 203-120x120-B-CW/EC	MATERIAL: 304L S.S.	QTY: 1
TOLERANCES	PART No.: V203C0C0B220XXXX00	TITLE: V203 CW 3_8 DISC 78 inch + (unique)-5131453-01	IDENTIFICATION: ---	DRAWING No.: 5131453-01-2	PAGE: 4 of 25
ANGLE : ±1°	UNITS : [mm]				
FRACTION : ±1/8"	UNITS : [mm]				
.XX : ±0.015"	UNITS : [mm]				
.XXX : ±0.005"	UNITS : [mm]				

- (01) SEE DWG. E-46091
- (02) 2" SQUARE SOCKET (E-23061)
- (03) H.H.C.S. 0.38 X 1.00 L.G. (2 REQ'D)

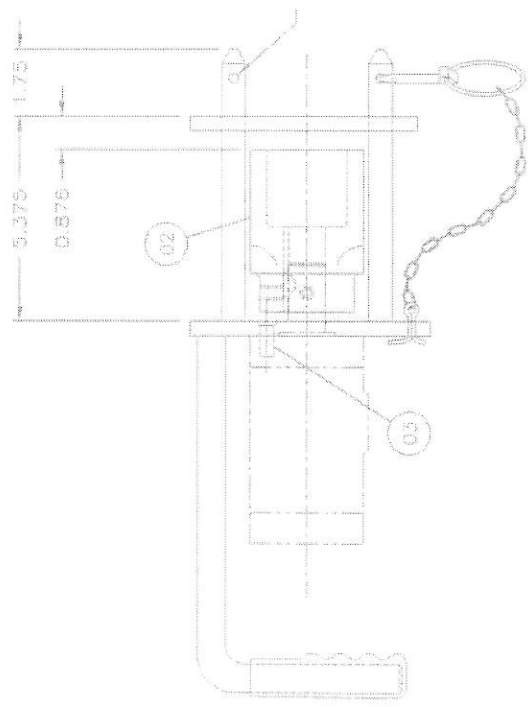

4 RODS - 0.625 DIA. DR
A 5.51 O.B.C. STRADDLE

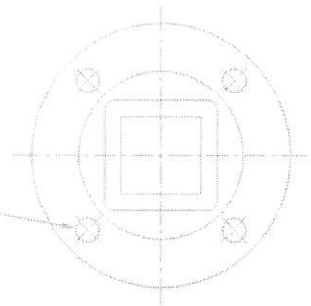

CROSS DRILLED HOLES
FOR RETAINING PIN

THIS DRAWING IS THE PROPERTY OF RODNEY HUNT COMPANY (RHC). ACCEPTANCE OF THIS DRAWING CONSTITUTES AGREEMENT. (1) THAT IT AND ANY COPIES THEREOF SHALL NOT BE TRANSMITTED OR EXHIBITED TO OTHERS. (2) THAT IT AND ANY COPIES THEREOF SHALL BE RETURNED UPON REQUEST BY RHC AND (3) THAT THE INFORMATION APPEARING HEREON IS CONFIDENTIAL AND IS NOT TO BE DISCLOSED TO OTHERS WITHOUT RHC'S WRITTEN PERMISSION FROM RHC.	
RODNEY HUNT COMPANY ORANGE, MA 01364-1251	
ASSEMBLY: MODEL 25PD FOR OPERATION OF HOIST WITH F14 FLANGE	ORDER NO. DWG NO. E-46091
DRAWN: SLR	DESIGNED: RWK
CHECKED: J. S.	APPROVED:
DATE: 3/16/96	SCALE: NTS

TOLERANCE UNLESS OTHERWISE SPECIFIED		ALT.	BY	CHKD	DATE
SEC.	DIM.	MACHINE	CAST	FABRICATE	
1	PLACE	±0.060	±0.250	±0.250	
2	PLACE	±0.030	±0.125	±0.125	
3	PLACE	±0.015	±0.060	±0.060	
	ANGLE	±1°	±2°	±2°	

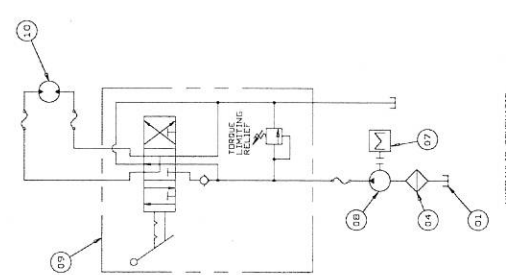

HYDRAULIC SCHEMATIC

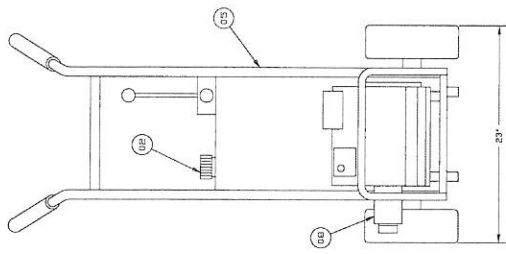
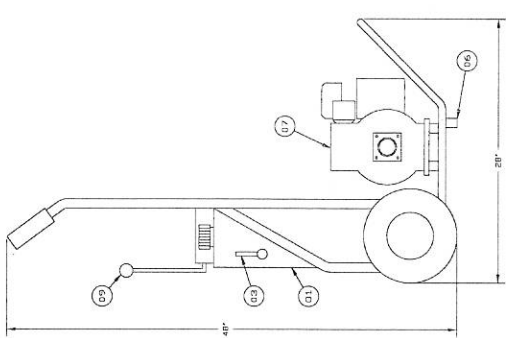

CONSERVATIVE COMPANY, ROSELAND, N.J. UNIT
 CUSTOMER REQUIREMENT'S MAY VARY FROM HAZARD
 ALTERNATIONS CAPABLE WEIGHT 185 LBS W/ROLLS

- 01) RESERVOIR
- 02) FILTER BREATHER
- 03) SIGHT GAGE
- 04) STRAINER
- 05) MAINFRAME FABRICATION
- 06) BUMPER
- 07) GAS ENGINE
- 08) HYDRAULIC MOTOR
- 09) DIRECTIONAL VALVE
- 10) HYDRAULIC MOTOR

SHEET 1 OF 1

RODNEY HUNT COMPANY ORANGE, MA. 01364-1251

ASSEMBLY: ENGINE DRIVEN
 HYDRAULIC PORTABLE OPERATOR
 MODEL 25

DESIGNED: JFR DATE: 6/1/90
 CHECKED: APPROVED: SCALE: N.T.S.
 ORDER NO. 2490 DWG. NO. C-70929

REV	DATE	BY	DATE
1	6/1/90	JFR	
2			
3			
4			

CHANGE
 REFRESHED ORIGINAL DESIGN

Issued